



DESIGN PACKAGE C134 TOTTENHAM COURT ROAD STATION

Option D1.8 Pedestrian Modelling Report

Document Number: C134-OVE-T3-RGN-N105-50006

Document History:

Revision:	Date:	Prepared by:	Checked by:	Authorised by:	Reason for Issue:
3.0	10-02-11	[REDACTED]	[REDACTED]	[REDACTED]	For Review
		[REDACTED]	[REDACTED]	[REDACTED]	

This document contains proprietary information. No part of this document may be reproduced without prior written consent from the chief executive of Crossrail Ltd.



Project title	C134 Tottenham Court Road Station	Job number	211700
Document title	Option D1.8 – Pedestrian Modelling Report	File reference	4-10
Document ref	C134-OVE-T3-RGN-N105-50006		

Revision	Date	Filename	C134-OVE-T3-RGN-N105-50006 Option D1.8 Pedestrian Modelling Report		
1.0	04/02/11	Description	For Review		
			Prepared by	Checked by	Approved by
		Name	[Redacted]	[Redacted]	[Redacted]
		Signature			
2.0	08/02/11	Filename	C134-OVE-T3-RGN-N105-50006 Option D1.8 Pedestrian Modelling Report_Rev2.0		
		Description	For Review		
			Prepared by	Checked by	Approved by
		Name	[Redacted]	[Redacted]	[Redacted]
		Signature			
3.0	10/02/11	Filename	C134-OVE-T3-RGN-N105-50006 Option D1.8 Pedestrian Modelling Report_Rev3.0		
		Description			
			Prepared by	Checked by	Approved by
		Name	[Redacted]	[Redacted]	Graham Williams
		Signature	[Redacted]	[Redacted]	[Redacted]

Issue Document Verification with Document

Executive Summary

Background and Scope

Pedestrian modelling study was undertaken in September 2010 for the RIBA E layout of Tottenham Court Road station using the 2026 forecast passenger demand from CPFR 5.0. The Legion modelling assumptions, results and conclusions from this study were reported in C134-OVE-T3-RAN-N105-00004.

Following a review of the modelling results presented in the RIBA E Legion modelling report, C134 was further instructed by Crossrail to assess the impact of the Project Assure proposal of omitting the Western Ticket Hall to Central Line Link at TCR station.

As a result of the above structural change, the Western Entrance was reconfigured, allowing circulation from the ticket hall level directly to a new concourse at Crossrail Platform level. The mezzanine level of the Western TH (as shown in RIBA E design) was omitted.

Various design options were proposed by C134 in relation to the reconfiguration of the Western entrance and the Platform/ Passageway layouts. From a series of reviews, Option D1.8 was identified as the Preferred Design Option to be progressed and developed further.

In all the options, the ticket hall has been subject to minimal change such as the removal of a ticket gate and a PRM lift. The mezzanine level of the Western Ticket hall was omitted. As a result, the six escalators from the mezzanine level were also removed. PRM circulation between lifts was maintained through an open passageway adjacent to the escalator bank at the mezzanine level promoting equality of experience as far as possible between PRMs and escalator users. The single PRM lift at the Crossrail platform level faces onto the concourse and has a recessed lobby.

The purpose of this study is to assess the operational capacity of Option D1.8 at TCR West resulting from the permanent omission of the Central Line Link. The Legion models used in this study are from TCR Station's RIBA E design stage and have been jointly audited by CRL/LU.

Modelling Inception Meeting

An inception meeting was held with London Underground on 30th January 2011 to discuss the modelling methodology and assumptions for the Legion modelling study of Option D1.8. In the meeting, it was agreed that the 2026 passenger demand matrices in CPFR 5.0 will be adjusted to allow for the omission of the Central Line Link and subsequent re-routing of passengers. The Central line to/from Western Entrance passengers were moved to the Eastern Entrance. In addition, 3,150 passengers were added to the Western Entrance due to the excess variation in flows from the two Crossrail platforms.

The revised passenger demand matrices were supplied by Crossrail and were agreed with LU prior to modelling. Revised Matrices and a note from Crossrail are attached in Appendix A.

Modelling Outputs

The following Legion modelling outputs are presented in this report:

- Cumulative Mean Density (CMD) maps
- Cumulative High Density (CHD) maps
- Desire Line Diagrams

Cumulative Mean Density (CMD) maps are based on Fruin's Levels of service (LoS) for walkways, queuing and stairways for the peak 15 minutes.

Cumulative High Density (CHD) maps show the total time the passenger density exceeds a given threshold (1.08 passengers/m² and 1.54 passengers/m² as requested by LU).

The Level of Service maps produced by Legion were assessed using LU's 1-371 Standard and Crossrail's Station Planning: Platforms, CR-STD-305, V6, to ensure the station layout satisfies the design criteria.

Results

The results of Option D1.8 models are compared with the RIBA E design layout.

However, it should be noted that the passengers demand used in this study is higher than the demand in RIBA E models for the two ticket halls and Crossrail part of the station. A graph showing the change in demand is presented in **Figure 1**.

Therefore, an equivalent comparison is feasible only for the Central Line and Northern Line platforms and circulation areas.

Figure 1: Change in Demand (Option D1.8) from CPFR 5.0

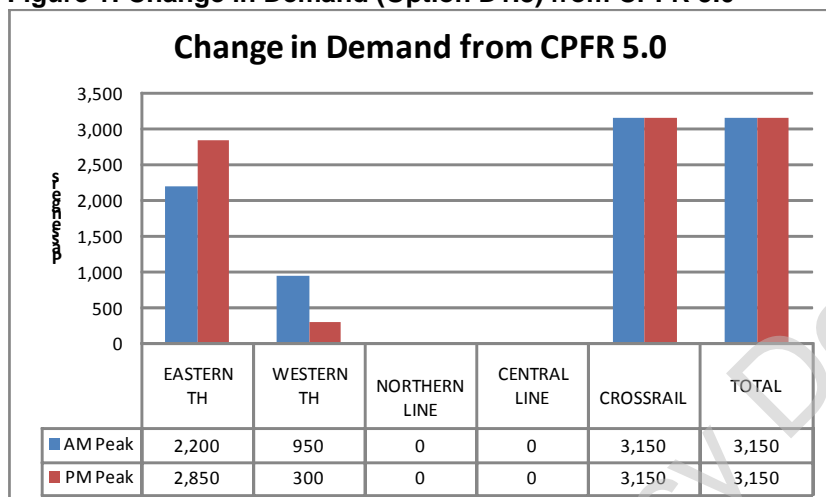

From the outputs of Legion models, it was observed that the pedestrian areas within the proposed station complex generally satisfied Level of Service (LoS) criteria defined within the LU's 1-371 and Crossrail's Pedestrian Modelling Guidelines (CR/QMS/OPS/GN/0010) and were not significantly different from the RIBA E design.

In summary, the following points are noted:

1. Passenger density plots for the Eastern Ticket Hall do not show any congestion during the morning and evening peak periods even with the additional Central Line passengers being re-routed from the western entrance. The escalators, stairways and ticket gates have sufficient capacity to cater for peak passenger flows at up to 2026 +28% demand levels;
2. The cumulative mean density maps show that the Crossrail platforms and the passageways to/from the platforms are adequately designed and sized to accommodate up to 2026 +28% passenger demand levels;
3. However, it was observed that a small area within the western most adit from the westbound platform shows Walkway LoS D in the AM+28% scenario resulting from heavy flow of passengers from the initial four carriages of the westbound train;
4. The Northern Line platforms operate at acceptable levels of service. Some intermittent congestion was observed on the middle stairs within the LU's TCR upgrade scheme, which relatively clears in a short period without causing major operational disruptions to the rest of the station;
5. No significant impact on the passenger levels of service within the Central Line Concourse and Central Line Platform; and
6. Congestion was observed at the gateline of the Western TH and at the foot of the escalators in the western concourse resulting from the additional 3,150 passengers in the matrices. Passenger management such as a temporary barrier in the peak periods is recommended at the

foot of the escalators to separate the entry and exit flows in order to improve circulation in the lower concourse.

In general, it was observed that the Project Assure proposal of omitting the Central Line Link from Western Ticket Hall has no adverse impact on the Eastern Ticket Hall and the Central Line concourse. The density maps showed that the passenger levels of service in these areas of the station are within the LU/CRL acceptable limits.

Learning Legacy Document

Contents

Abbreviations used in this report	8
1 Introduction	9
2 Passenger Demand Matrices.....	9
3 Model Layout	11
4 Key Changes to the Modelling Assumptions.....	12
4.1 Central Line.....	12
4.1 Boarding Profile for PRMs - Crossrail West	13
4.2 Passenger Routing Options – Western TH to Crossrail EB Platform	14
5 Modelling Scenarios	14
6 Legion Modelling Outputs	15
7 Results	16
7.1 Central Line Platforms and Interchange Connections	17
7.2 Northern Line Platforms and Interchange Connections	27
7.3 Western Ticket Hall	30
7.4 Eastern Ticket Hall	30
7.5 Crossrail Platform Level	30
8 Summary and Conclusions	30
9 Reference Documents	30
10 Appendix A: Option D1.8 Adjusted 2026 Demand Note from CRL (Charles Harmer).....	30
11 Appendix B: Peak 15 minutes Cumulative Mean Density (CMD) Maps – Queuing Levels of Service	30
11.1 2026 AM Peak +28%	30
11.2 2026 PM Peak +28%	30
12 Appendix C: Peak 15 minutes Cumulative Mean Density (CMD) Maps – Staircase Levels of Service	30
12.1 2026 AM Peak +28%	30
12.2 2026 PM Peak +28%	30
13 Appendix D: Peak 15 minutes Cumulative High Density (CHD) Maps – 1.08 passengers/m²	30
13.1 2026 AM Peak +28%	30
13.2 2026 PM Peak +28%	30
14 Appendix E: Peak 15 minutes Cumulative High Density (CHD) Maps – 1.54 passengers/m²	30
14.1 2026 AM Peak +28%	30



14.2	2026 PM Peak +28%	30
15	Appendix F: 'With Signage' Routing Scenario – Western Entrance	30
15.1	Introduction.....	30
15.2	Results.....	30
16	Appendix F: Static Analysis – TCR West	30
16.1	Static Analysis	30
16.2	Analysis area	30
16.3	Line 2 Demand	30
16.4	Comparison of Crossrail and Line 2 demand.....	30
16.5	Routing Assumptions	30
16.6	Results.....	30
16.7	Summary	30

Learning Legacy Document

Abbreviations used in this report

CMD	Cumulative Mean Density
CPFR	Crossrail Programme Functional Requirements
CRL	Crossrail Limited
EB	Eastbound
FDC	Framework Design Consultant
IR3	Interim Review 3
LoS	Levels of Service
LU	London Underground
PED	Platform Edge Door
PRM	Person with Restricted Mobility
SD3	Scheme Design 3
TCR	Tottenham Court Road
TfL	Transport for London
TH	Ticket Hall
WAG	Wide Aisle Gate
WB	Westbound

Learning Legacy Document

1 Introduction

The purpose of this report is to assess the operational capacity of Option D1.8 at TCR West resulting from the permanent omission of the Central Line Link. Additionally, to inform the impact of increasing the passenger demand (by 3,150 passengers) from Crossrail EB to Western TH in the AM peak and Western TH to Crossrail WB in the PM peak due to excess variation in flows between the two Crossrail platforms as suggested by Crossrail.

2 Passenger Demand Matrices

The passenger demand used in this study is the CPFR 5.0 matrices adjusted by transferring the Western Ticket Hall to/from Central Line flows to the Eastern Ticket Hall as suggested by LU/CRL. The original matrices from CPFR 5.0 are shown in **Tables 1** and **2**. The adjusted matrices issued by Crossrail for the purposes of this study are shown in **Tables 3** and **4**.

Table 1: Passenger Demand Matrices (CPFR 5.0) – 2026 AM Peak (07:00 to 10:00 hours)

2026 AM Matrix (with Central Line Link)	TCR EASTERN SE	TCR DEAN ST SE	TCR NORTHERN (NB)	TCR NORTHERN (SB)	TCR CENTRAL (EB)	TCR CENTRAL (WB)	TCR CROSSRAIL (EB)	TCR CROSSRAIL (WB)	TOTAL
TCR EASTERN SE	0	0	250	300	300	300	500	350	2,000
TCR DEAN ST SE	0	0	0	0	150	0	200	0	350
TCR NORTHERN (NB)	3,400	0	0	0	1,050	400	650	450	5,950
TCR NORTHERN (SB)	1,900	0	0	0	2,550	1,950	2,900	1,800	11,100
TCR CENTRAL (EB)	2,000	400	750	250	0	0	0	0	3,400
TCR CENTRAL (WB)	2,350	1,650	850	0	0	0	0	0	4,850
TCR CROSSRAIL (EB)	2,600	350	1,300	800	0	0	0	0	5,050
TCR CROSSRAIL (WB)	5,800	7,700	750	1,800	0	0	0	0	16,050
TOTAL	18,050	10,100	3,900	3,150	4,050	2,650	4,250	2,600	48,750

Table 2: Passenger Demand Matrices (CPFR 5.0) – 2026 PM Peak (16:00 to 19:00 hours)

2026 PM Matrix (with Central Line Link)	TCR EASTERN SE	TCR DEAN ST SE	TCR NORTHERN (NB)	TCR NORTHERN (SB)	TCR CENTRAL (EB)	TCR CENTRAL (WB)	TCR CROSSRAIL (EB)	TCR CROSSRAIL (WB)	TOTAL
TCR EASTERN SE	0	0	2,700	1,500	1,800	2,700	6,450	2,900	18,050
TCR DEAN ST SE	0	0	0	0	1,250	500	8,550	350	10,650
TCR NORTHERN (NB)	2,800	0	0	0	0	550	2,400	1,050	6,800
TCR NORTHERN (SB)	3,650	0	0	0	1,600	1,200	1,000	1,750	9,200
TCR CENTRAL (EB)	2,750	150	2,250	1,250	0	0	0	0	6,400
TCR CENTRAL (WB)	1,900	950	2,100	1,950	0	0	0	0	6,900
TCR CROSSRAIL (EB)	2,450	150	2,400	600	0	0	0	0	5,600
TCR CROSSRAIL (WB)	3,650	1,600	3,850	850	0	0	0	0	9,950
TOTAL	17,200	2,850	13,300	6,150	4,650	4,950	18,400	6,050	73,550

Re-routing of Central Line passengers from the Western Ticket hall to the Eastern ticket hall has resulted in an increase of 2,200 passengers (150 Entry and 400+1,650 Exit) in the Eastern Ticket Hall in the morning peak and increase of 2,850 (1,250+500 Entry and 150+950 Exit) passengers in the evening peak.

In addition to the above changes, 350 passengers from Crossrail EB to Western TH in the morning peak matrix of CPFR 5.0 was increased to 3,500. The same proportion was applied to the Western TH to Crossrail WB flows in the evening peak.

The adjusted passenger figures are highlighted in **Tables 3 to 4**.

Table 3: Adjusted Matrix – 2026 AM Peak (07:00 to 10:00 hours)

2026 With Crossrail - AM Peak Period Demand at Tottenham Court Road									
TCR XR153Ru AM	T C R EASTERN SE	T C R DEAN ST SE	T C R NORTHERN (NB)	T C R NORTHERN (SB)	T C R CENTRAL (EB)	T C R CENTRAL (WB)	T C R CROSSRAIL (EB)	T C R CROSSRAIL (WB)	TOTAL
T C R EASTERN SE	-	-	250	300	450	300	500	350	2150
T C R DEAN ST SE	-	-	-	-	-	-	200	0	200
T C R NORTHERN (NB)	3400	-	-	-	1050	400	650	450	5950
T C R NORTHERN (SB)	1900	-	-	-	2550	1950	2900	1800	11100
T C R CENTRAL (EB)	2400	-	750	250	-	-	-	-	3400
T C R CENTRAL (WB)	4000	-	850	0	-	-	-	-	4850
T C R CROSSRAIL (EB)	2600	3500	1300	800	-	-	-	-	8200
T C R CROSSRAIL (WB)	5800	7700	750	1800	-	-	-	-	16050
TOTAL	20100	11200	3900	3150	4050	2650	4250	2600	51900

Table 4: Adjusted Matrix – 2026 PM Peak (16:00 to 19:00 hours)

2026 With Crossrail - PM Peak Period Demand at Tottenham Court Road									
TCR XR153Ru PM	T C R EASTERN SE	T C R DEAN ST SE	T C R NORTHERN (NB)	T C R NORTHERN (SB)	T C R CENTRAL (EB)	T C R CENTRAL (WB)	T C R CROSSRAIL (EB)	T C R CROSSRAIL (WB)	TOTAL
T C R EASTERN SE	-	-	2700	1500	3050	3200	6450	2900	19800
T C R DEAN ST SE	-	-	-	-	-	-	8550	3500	12050
T C R NORTHERN (NB)	2800	-	-	-	0	550	2400	1050	6800
T C R NORTHERN (SB)	3650	-	-	-	1600	1200	1000	1750	9200
T C R CENTRAL (EB)	2900	-	2250	1250	-	-	-	-	6400
T C R CENTRAL (WB)	2850	-	2100	1950	-	-	-	-	6900
T C R CROSSRAIL (EB)	2450	150	2400	600	-	-	-	-	5600
T C R CROSSRAIL (WB)	3650	1600	3850	850	-	-	-	-	9950
TOTAL	18300	1750	13300	6150	4650	4950	18400	9200	76700

3 Model Layout

Figure 2 shows C134's Tottenham Court Road station layout in RIBA E design stage, which consists of the two ticket halls, Northern Line, Central Line and Crossrail platforms and the interchange connections. The layout also includes the London Underground's proposed TCR upgrade scheme.

Figure 2: Tottenham Court Road Station Layout - Stage E

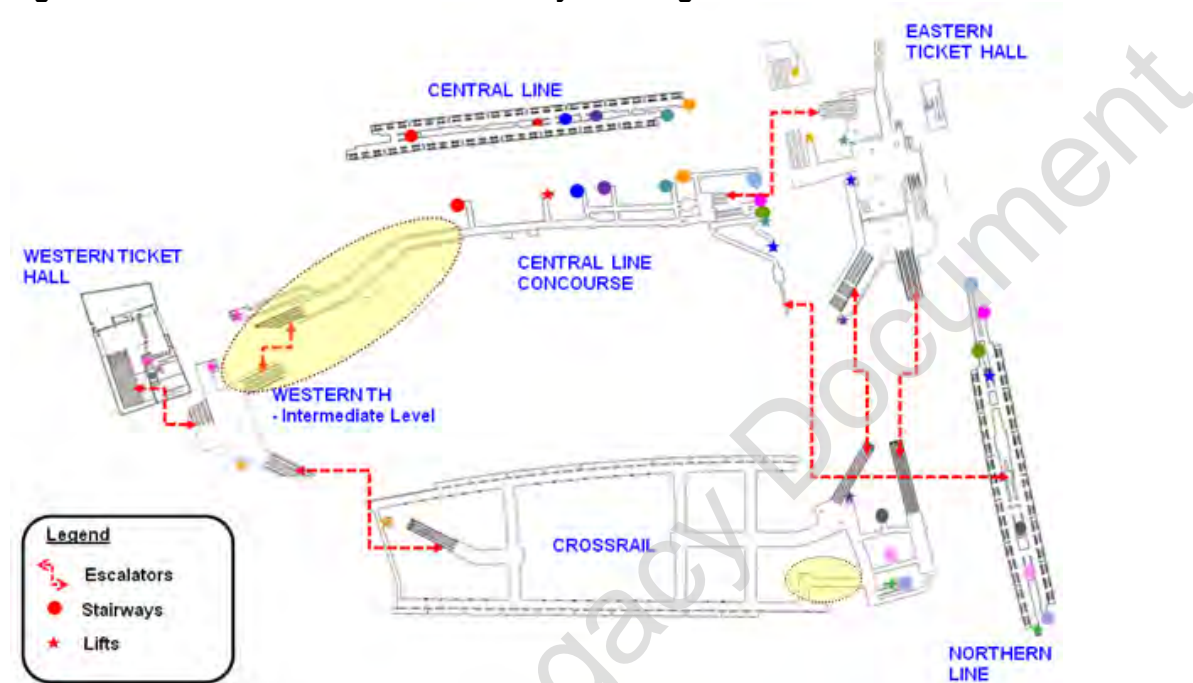

Figure 3 shows the Option D1.8 layout modelled in this study.

The main structural changes to the Stage E layout are as below:

- Deletion of the Western Ticket Hall to Central Line Link
- Omission of the mezzanine level of the Western Ticket Hall

Following the above structural changes, the Western Entrance was reconfigured, allowing circulation from the ticket hall level directly to a new concourse at Platform level.

Various design options were considered in relation to the reconfiguration of the Western entrance and the Platform/ Passageway layouts. From a series of reviews, Option D1.8 was identified as the Preferred Design Option to be progressed and developed further.

In the options proposed for the omission of the Central Line Link, the Western Ticket Hall has only been subject to minimal change such as the removal of a ticket gate and a PRM lift. The mezzanine level of the Western Ticket hall was omitted. As a result, the six escalators from the mezzanine level were also removed. PRM circulation between lifts was maintained through an open passageway adjacent to the escalator bank at the mezzanine level promoting equality of experience as far as possible between PRMs and escalator users.

The extended bank of escalators from the Western Ticket Hall arrive at a new concourse at Platform level. The single PRM lift faces onto the concourse and has a recessed lobby.

Figure 3: Tottenham Court Road Station Layout - Option D1.8

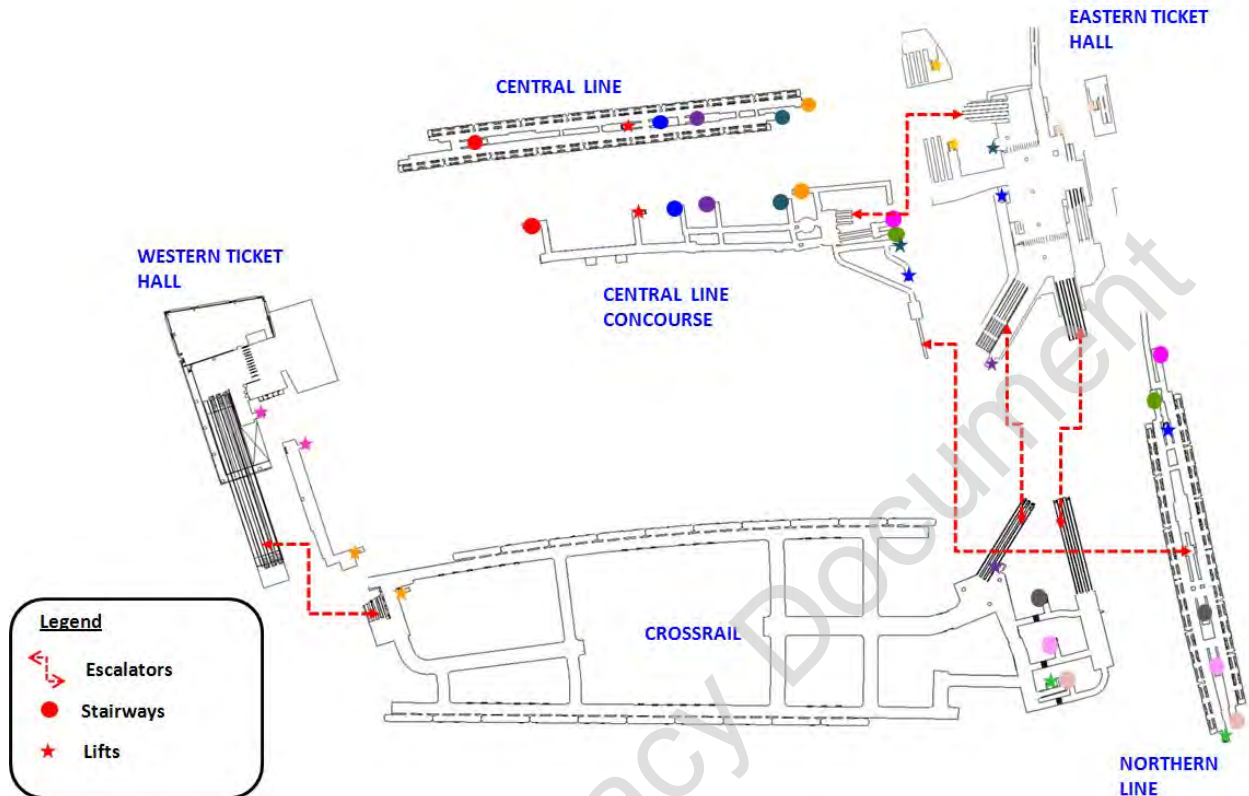

4 Key Changes to the Modelling Assumptions

The updated ACS (Assumptions Cover Sheets) for the 2026 +28% scenarios modelled were issued to CRL/LU. The ACS include all the key inputs and modelling assumptions such as boarding/alighting profiles, passenger arrival profiles, delay times for ticketing facilities, train timetables and so on.

Prior to commencing the Legion modelling study using the adjusted CPFR 5.0 demand, the following modelling assumptions were discussed with LU and CRL in an inception meeting and were agreed to be revised in the models.

4.1 Central Line

With the deletion of the Western Ticket Hall to Central Line link, the western most staircase on the Central Line platforms was redundant. Therefore, the staircase logic around the Central Line platform entry/exit points was re-assessed and agreed with LU and CRL prior to modelling. The proposed changes to the routing assumptions of Central Line stairways are shown in **Figure 4**.

Alighting passengers from the first two carriages of the Central Line westbound train, 50% passengers alighting from the seventh carriage and 100% from the eighth carriage of the Eastbound train to use the westernmost stair to exit the platforms as highlighted in Figure 4.

15% of the total passengers previously using the stairway adjacent to the lift will now use the westernmost staircase to access the Central Line platforms as agreed with LU.

Figure 4: Revised Passenger Routing Assumptions - Central Line

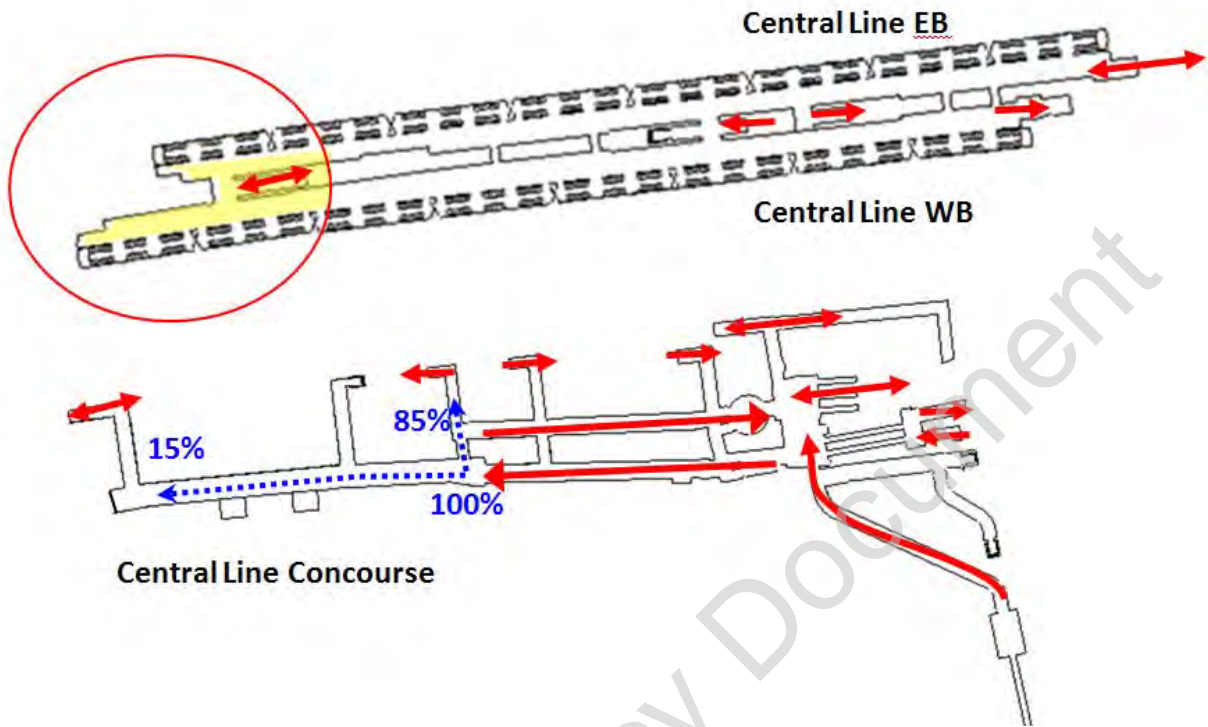

4.1 Boarding Profile for PRMs - Crossrail West

The Boarding Profile for PRMs at the western end of the Crossrail platforms as shown in **Figure 5**. These were supplied by LU and adopted in the Option D1.8 models. It was agreed that the CRL boarding/alighting profiles for non-PRMs remain constant as per original RIBA E audited models.

Figure 5: Revised Boarding Profiles - PRMs

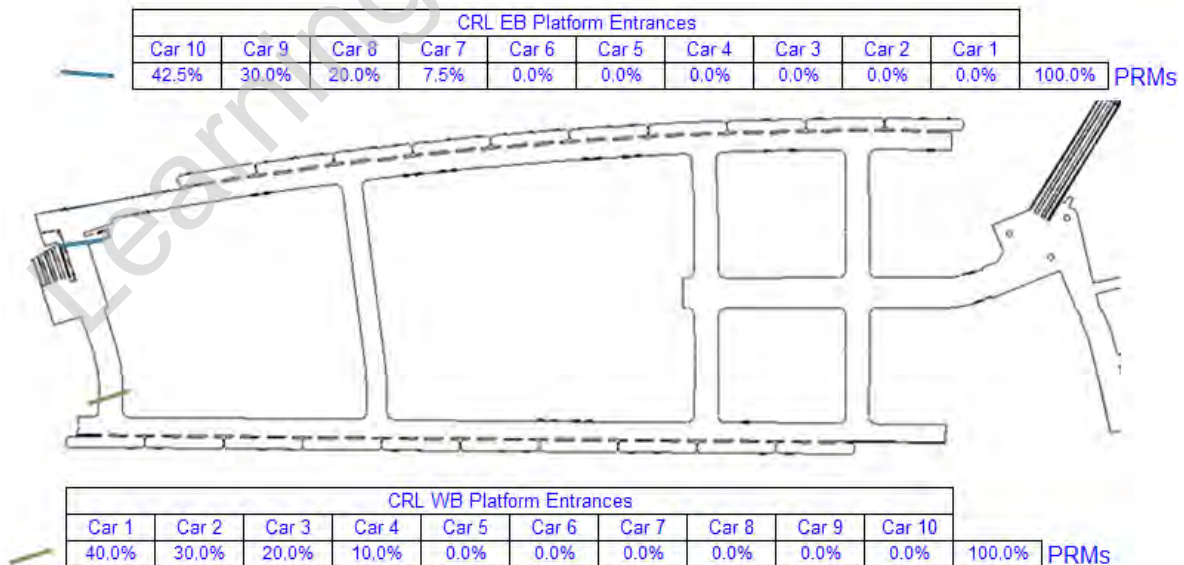

4.2 Passenger Routing Options – Western TH to Crossrail EB Platform

In the modelling inception meeting, LU suggested the following two routing scenarios to be tested for Option D1.8 as shown in **Figure 6**.

1. **Conservative Option** – 75% passengers use the shortest route from the western concourse to access the Crossrail EB platform and the remaining 25% use the adit.
2. **With Signage Option** – 85% passengers follow the signage and access the Crossrail EB platform using the central concourse and the adit and the remaining 15% use the shortest route via the western concourse. (Outputs and results from this routing scenario are reported in Appendix F)

Figure 6: Passenger Routing Options - Western TH to Crossrail EB

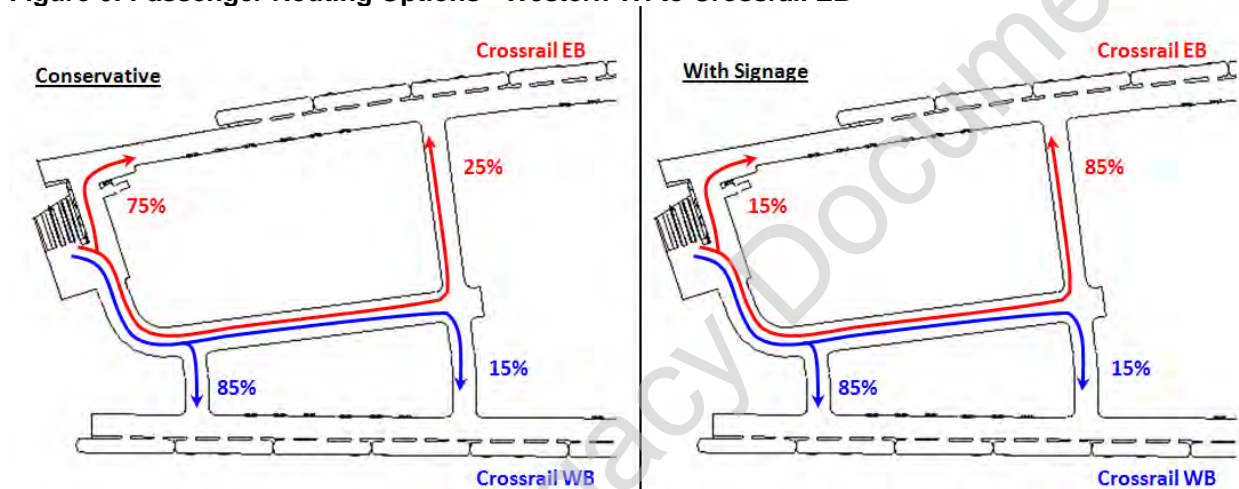

5 Modelling Scenarios

Legion Modelling was undertaken for the following two time periods:

- 2026 AM Peak +28% (07:00 to 10:00 hours)
- 2026 PM Peak +28% (16:00 to 19:00 hours)

6 Legion Modelling Outputs

The following Legion modelling outputs are presented in this report:

- Cumulative Mean Density (CMD) maps
- Cumulative High Density (CHD) maps
- Desire Line Diagrams

Cumulative Mean Density (CMD) maps are based on Fruin's Levels of service (LoS) for walkways, queuing and stairways for the peak 15 minutes.

Cumulative High Density (CHD) maps show the total time the passenger density exceeds a given threshold. (1.08 passengers/m² and 1.54 passengers/m² as requested by LU).

Level of Service (LoS) is used in pedestrian planning to indicate densities of pedestrians per square metre and from this, to classify conditions pedestrians' experience, in terms of freedom of movement and comfort.

LoS A (Blue) represents free-flow conditions whilst a LoS F (Red) indicates a very congested situation associated with the flow breakdown with many stoppages. **Figure 7** shows the thresholds applied for Walkway, Queuing and Stairway levels of service.

The Level of Service maps produced by Legion models were assessed using LU's 1-371 Standard and Crossrail's Station Planning: Platforms, CR-STD-305, V6, to ensure the station layout satisfied the design criteria.

Figure 7: Fruin's Levels of Service Thresholds

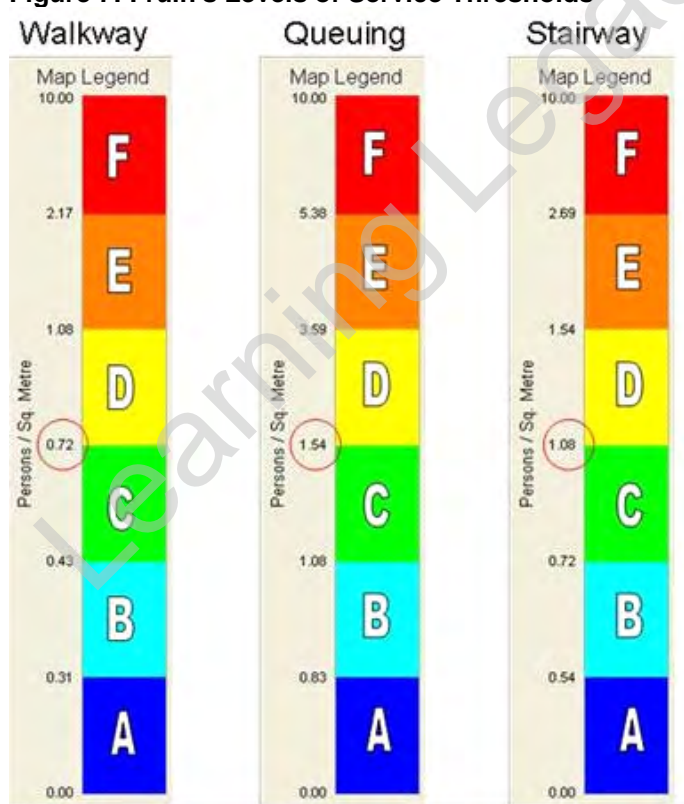

Table 5 shows London Underground's Levels of Service (Los) measures to apply to the four categories of station operation in the station areas listed.

Table 5: Planning Criteria and Levels of Service - London Underground's 1-371, August 2009

STATION AREA	NORMAL OPERATION (Levels of Service)	QUANTITATIVE MEASURE
Ticket Hall / Open Concourses Queuing for Ticket Hall facilities	Queuing LoS B Queuing LoS C	1.0m ² per person 0.8m ² per person
Passageways:		
One-way	Walkway LoS D	50 passengers /minute/metre width
Two-way	Walkway LoS C	40 passengers /minute/metre width
Stairways:		
One-way	Stairway LoS D	35 passengers /minute/metre width
Two-way	Stairway LoS C	28 passengers /minute/metre width
Escalators		100 passengers /minute/metre width
Platforms	Queuing LoS C	0.8m ² per person

7 Results

The Legion modelling results in this section are presented for the peak 15 minutes of the model runs for the Western Ticket Hall, Crossrail platforms/concourse level, Eastern Ticket Hall, Central Line and Northern Line for 2026 +28% demand levels for the AM (08:45 to 09:00 hours) and PM (17:45 to 18:00 hours) peak periods.

In order to assess the impact of the deletion of Central Line Link from the Western ticket hall, a detailed comparison of Legion outputs (Walkway, Queuing, Staircase LoS maps and CHD maps) for RIBA E and Option D1.8 schemes has been carried out in this section for Central Line platforms, connecting stairways and passageways as requested by LU.

CMD maps for Queuing and Staircase are included in Appendices B and C respectively. CHD maps are included in Appendices D and E of this report.

7.1 Central Line Platforms and Interchange Connections

7.1.1 AM Peak

Figure 8: 2026 AM Peak +28% (08:45 - 09:00 hours) CMD Walkway – Central Line Platforms and Concourse

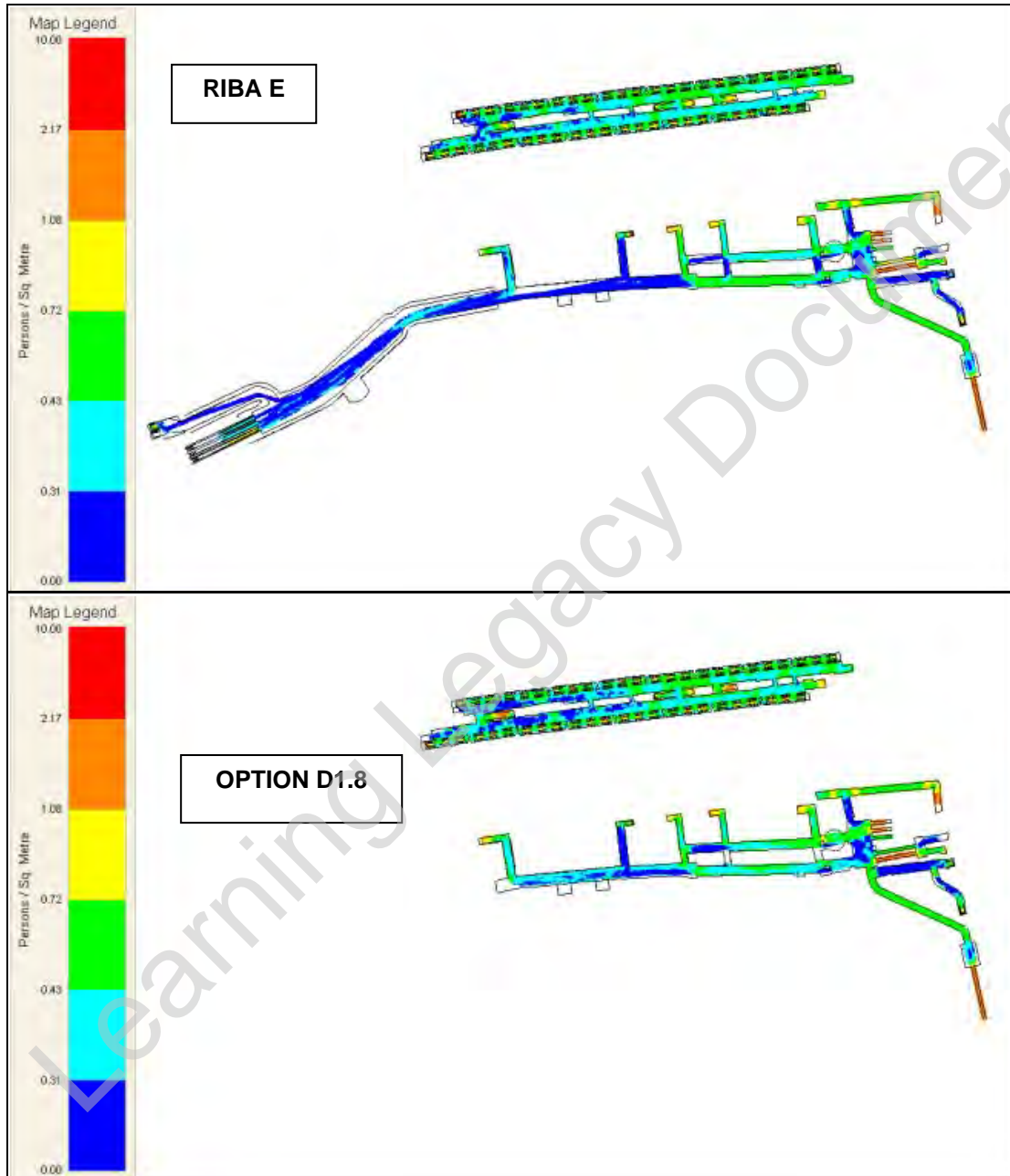

Figure 9: 2026 AM Peak +28% (08:45 - 09:00 hours) CMD Queuing – Central Line Platforms and Concourse

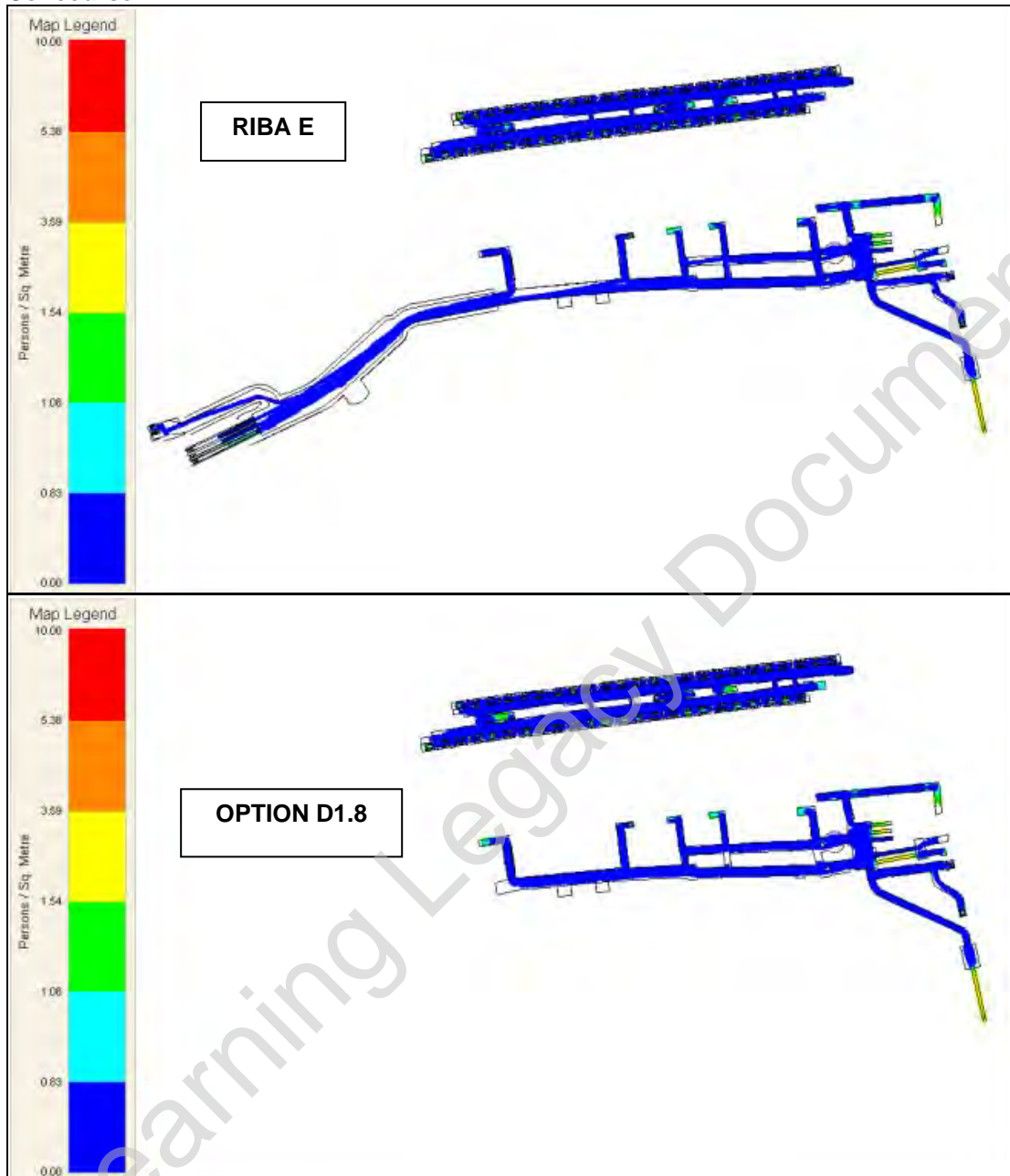

Figure 10: 2026 AM Peak +28% (08:45 - 09:00 hours) CMD Staircase – Central Line Platforms and Concourse

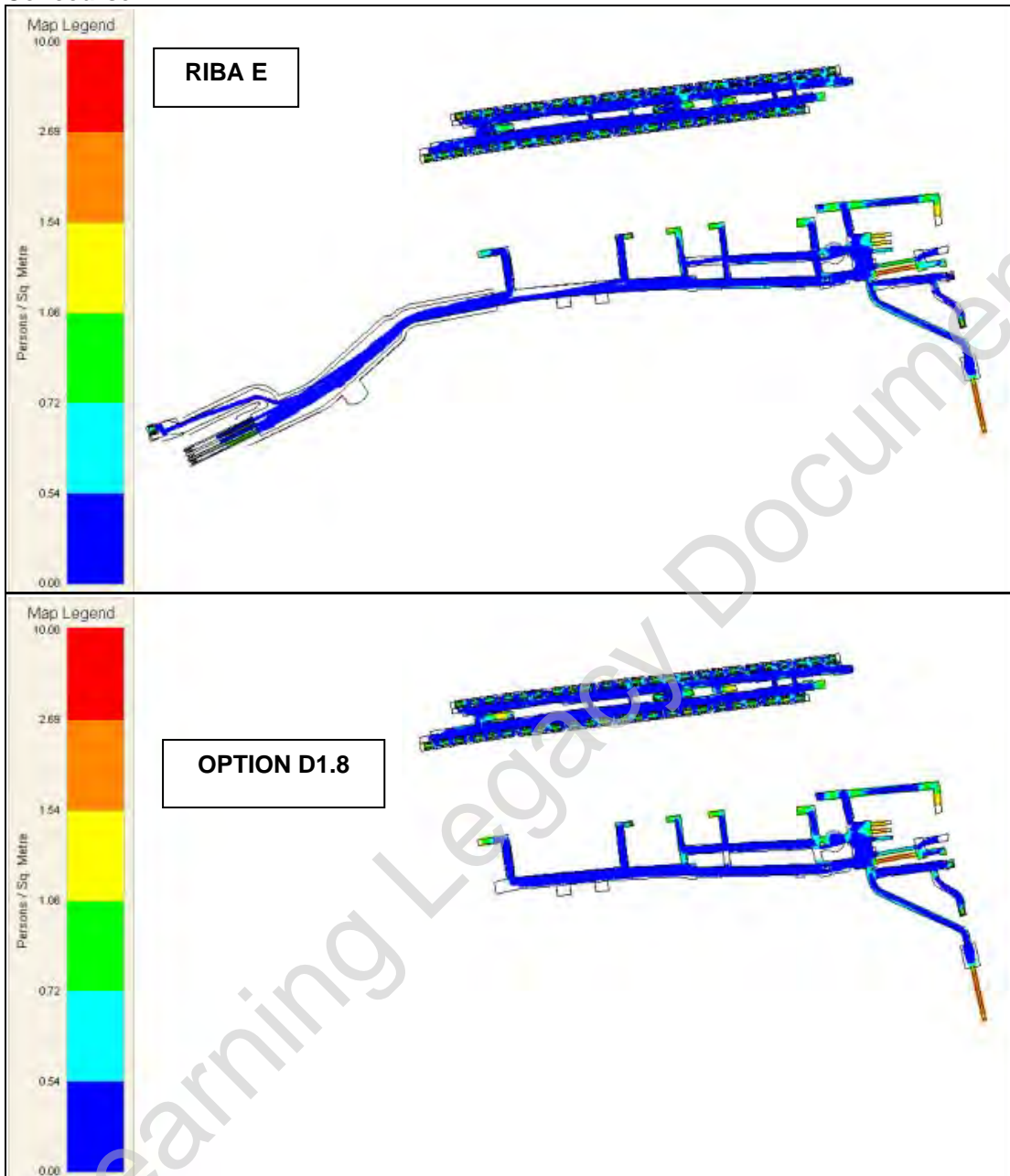

Figure 11: 2026 AM Peak +28% (08:45 - 09:00 hours) CHD 1.08 passengers/m² – Central Line Platforms and Concourse

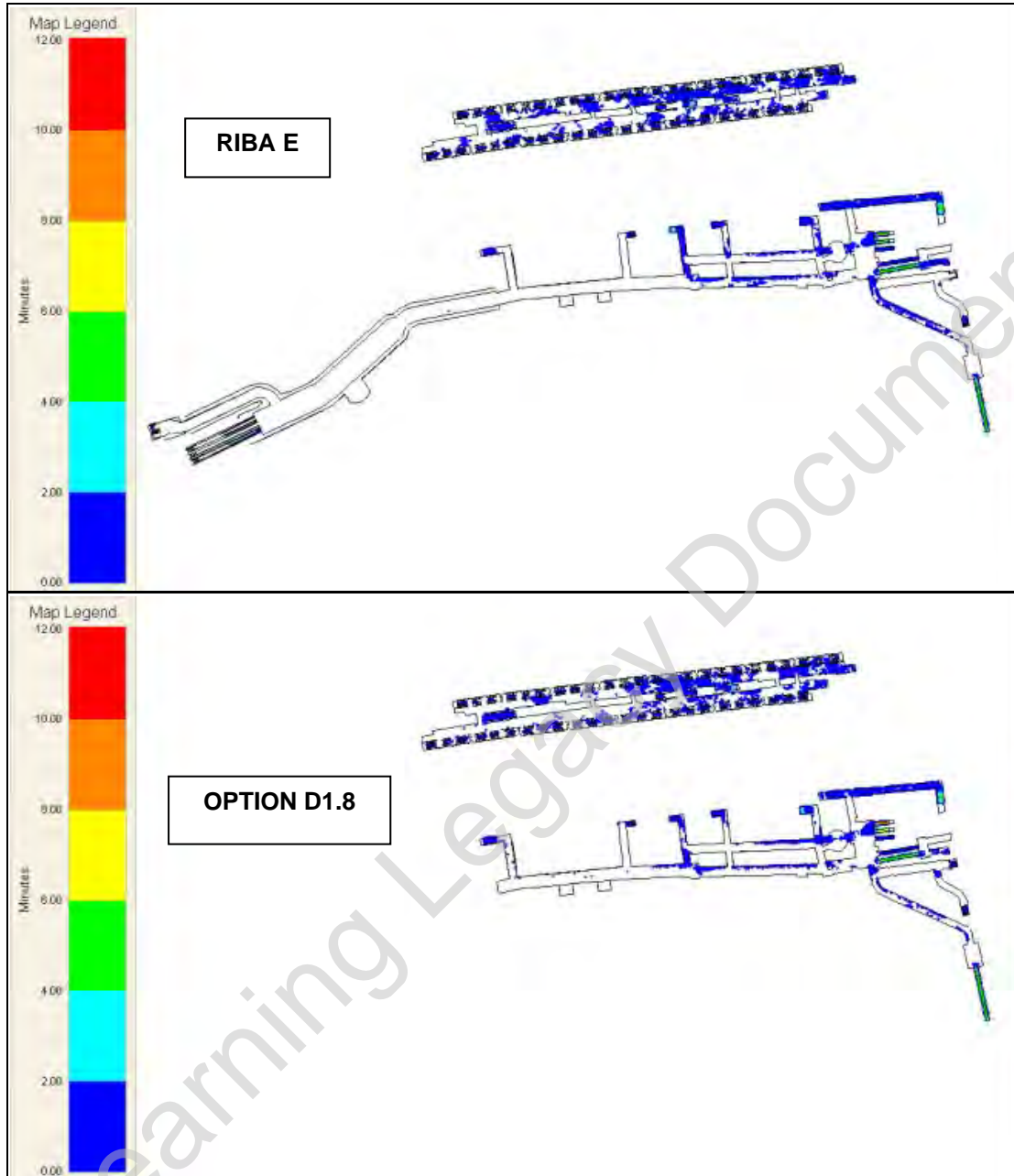
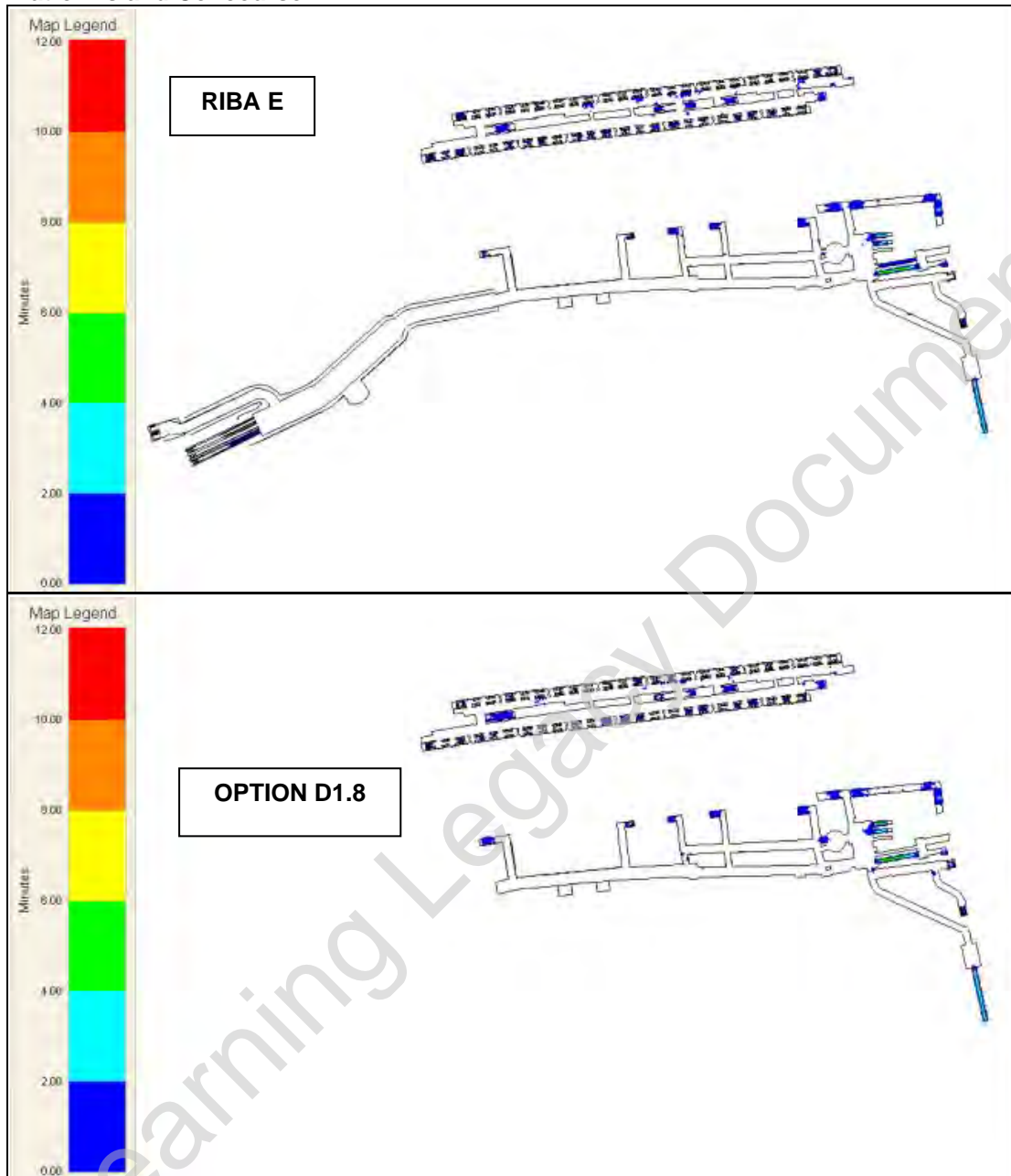

Figure 12: 2026 AM Peak +28% (08:45 - 09:00 hours) CHD 1.54 passengers/m² – Central Line Platforms and Concourse



7.1.2 PM Peak

Figure 13: 2026 PM Peak +28% (17:45 - 18:00 hours) CMD Walkway – Central Line Platforms and Concourse

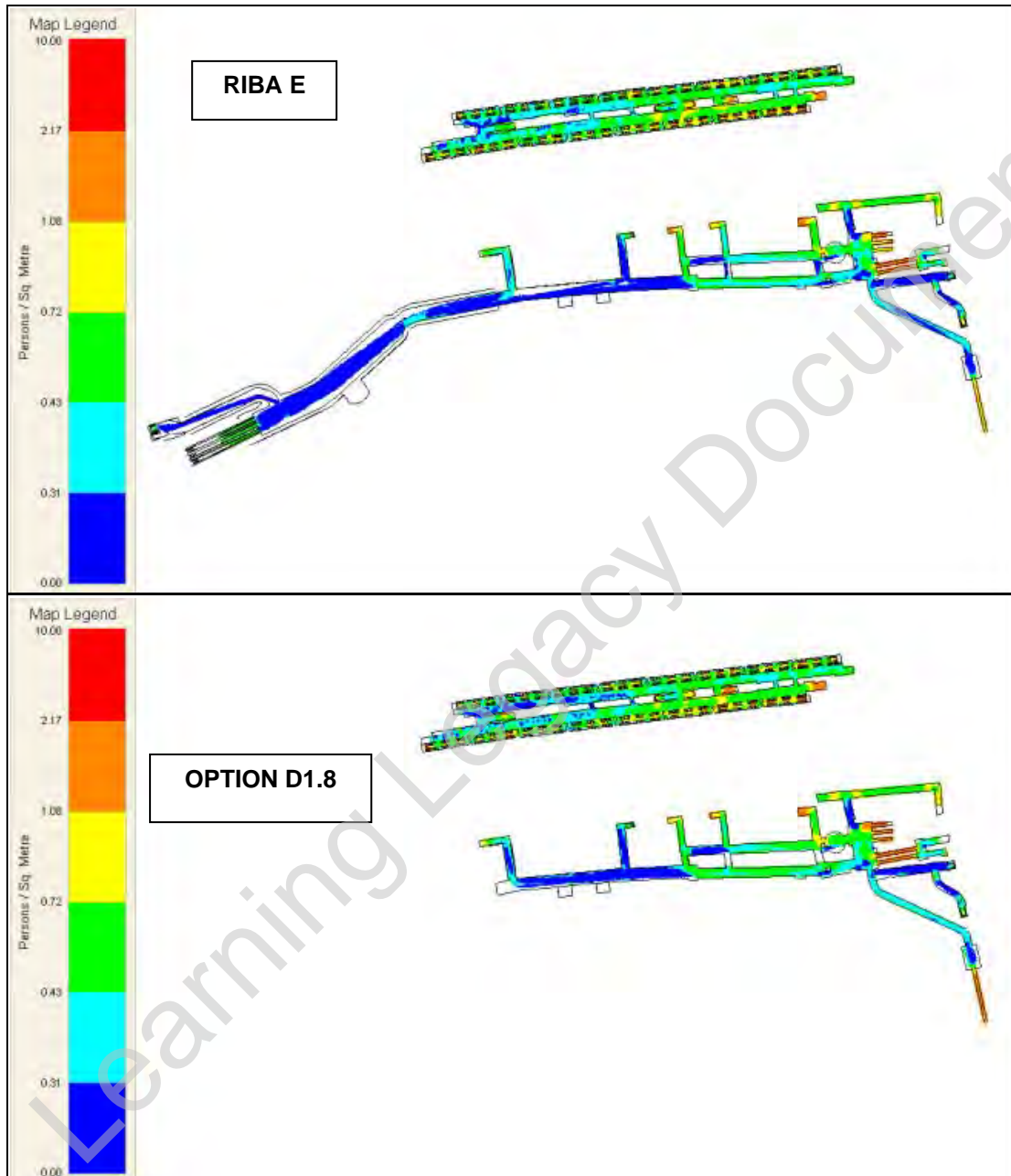

Figure 14: 2026 PM Peak +28% (17:45 - 18:00 hours) CMD Queuing – Central Line Platforms and Concourse

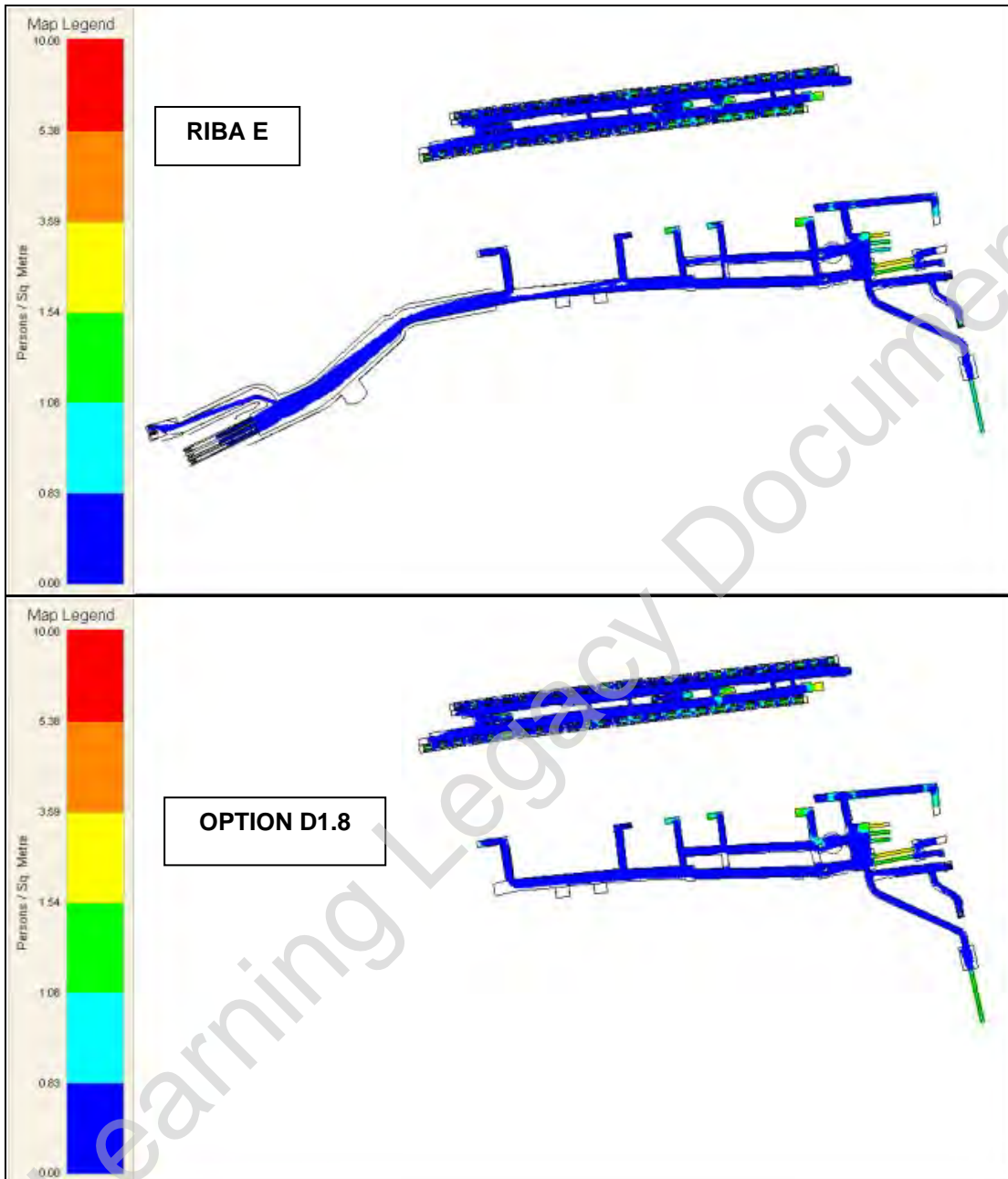

Figure 15: 2026 PM Peak +28% (17:45 - 18:00 hours) CMD Staircase – Central Line Platforms and Concourse

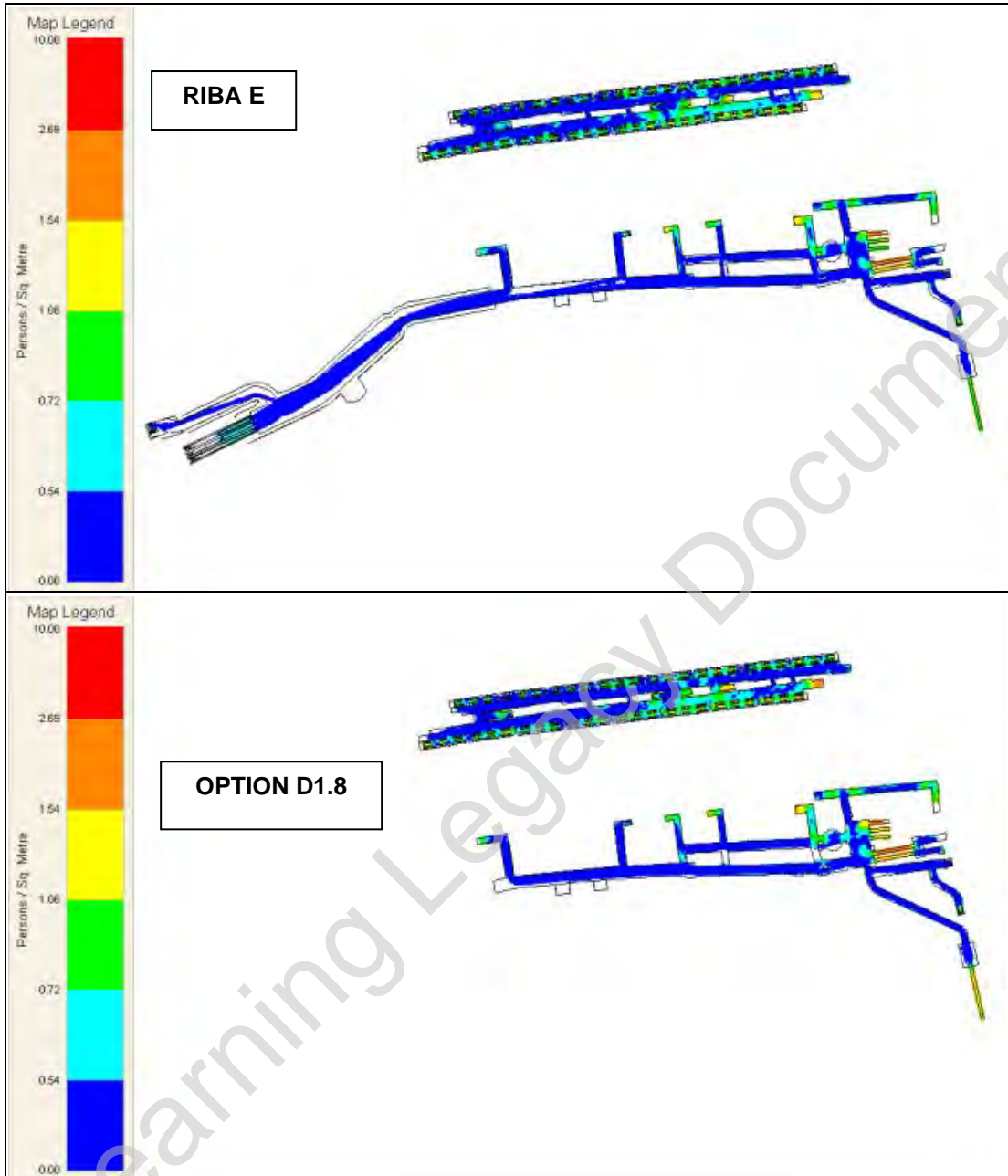

Figure 16: 2026 PM Peak +28% (17:45 - 18:00 hours) CHD 1.08 passengers/m² – Central Line Platforms and Concourse

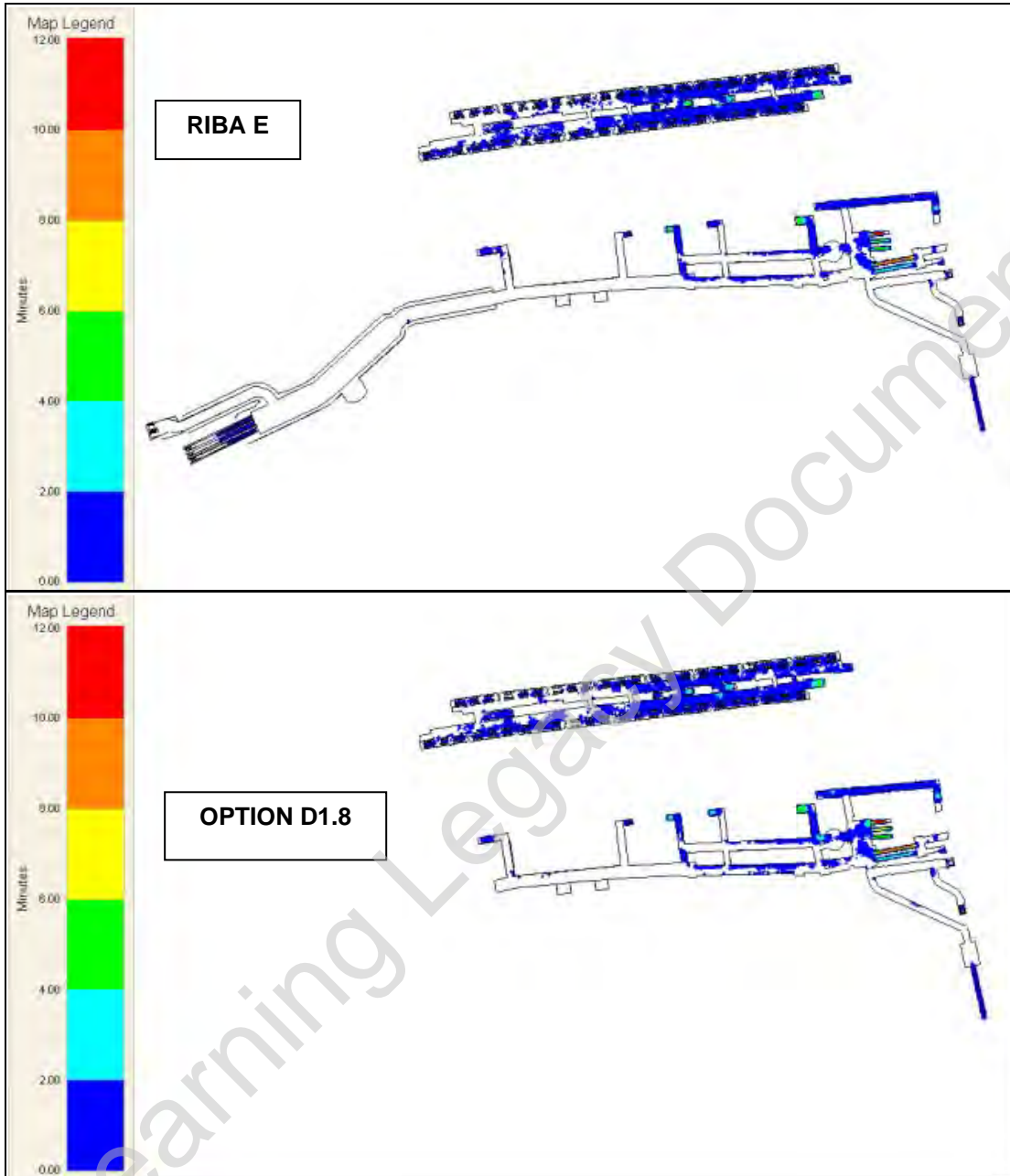
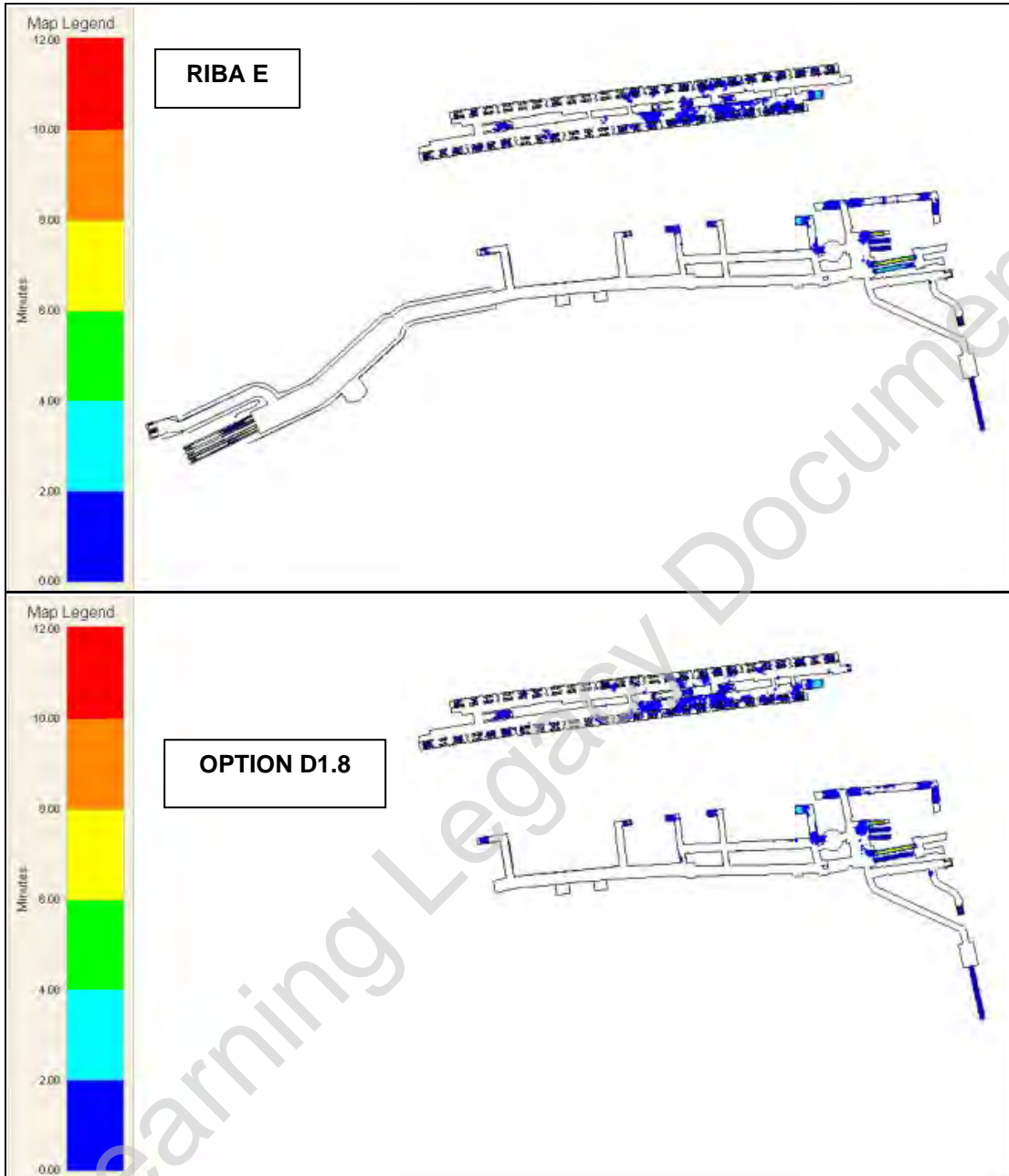

Figure 17: 2026 PM Peak +28% (17:45 - 18:00 hours) CHD 1.54 passengers/m² – Central Line Platforms and Concourse



Key inferences from the passenger density maps (CMD and CHD) for Central Line platforms and concourse areas for the 2026 +28% demand level for AM and PM peak periods are as follows:

1. The CMD map shows that Central Line platforms function satisfactorily during the AM and PM peak periods. The mean density maps for walkways show LoS C or better on the platforms;
2. The Central Line Concourse shows no noticeable congestion and has adequate capacity to accommodate passengers queuing to board the escalators and use the stairways without blocking any passageways or circulation areas;
3. The modelling results show that the vertical circulation elements such as escalators and stairways have sufficient capacity to cater for the 2026 +28% peak demand and are operating within the acceptable limits; and
4. The CMD and CHD maps for the two schemes (RIBE E and Option D1.8) show no significant difference in the results.

7.2 Northern Line Platforms and Interchange Connections

Passenger density map for Northern Line platforms and the interchange stairway connections for the AM and PM peak periods are shown in **Figures 18 to 21**.

CMD maps for Stairways are included in Appendix C.

CHD maps are included in Appendices D and E.

Figure 18: 2026 AM Peak +28% (08:45 - 09:00 hours) CMD Walkway – Northern Line

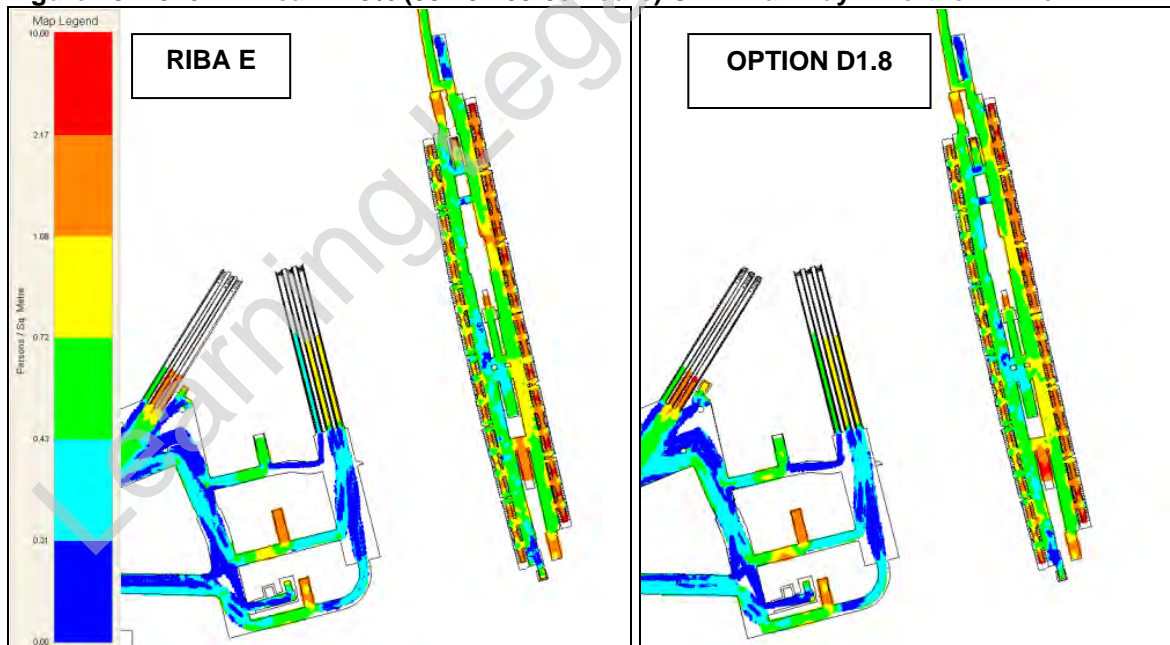
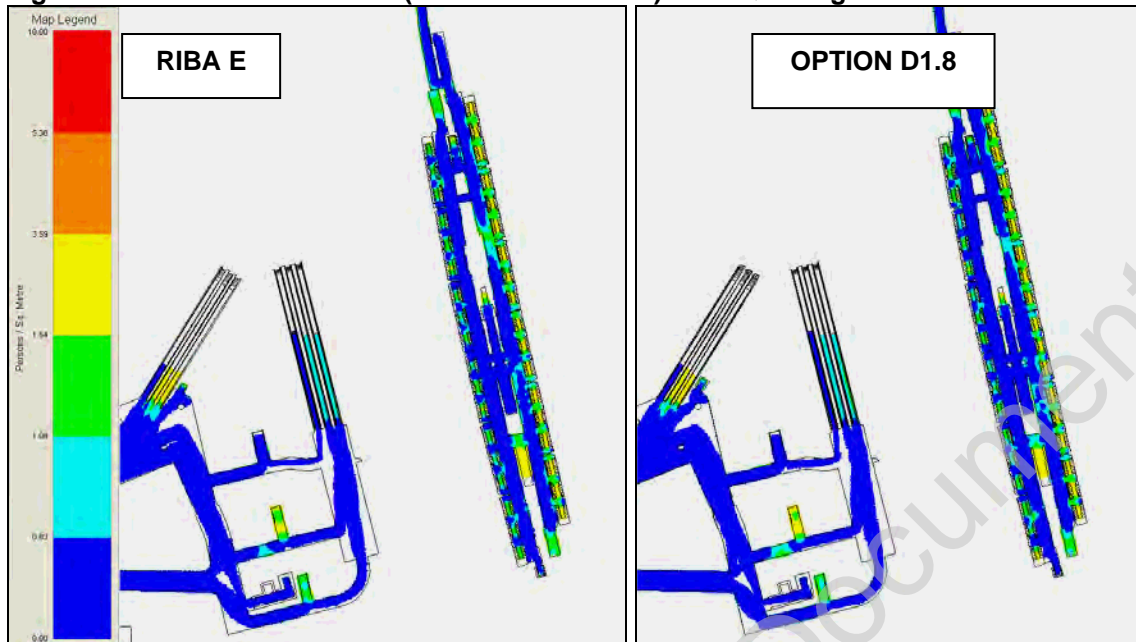

Figure 19: 2026 AM Peak +28% (08:45 - 09:00 hours) CMD Queuing – Northern Line



7.2.1 PM Peak

Figure 20: 2026 PM Peak +28% (17:45 - 18:00 hours) CMD Walkway – Northern Line

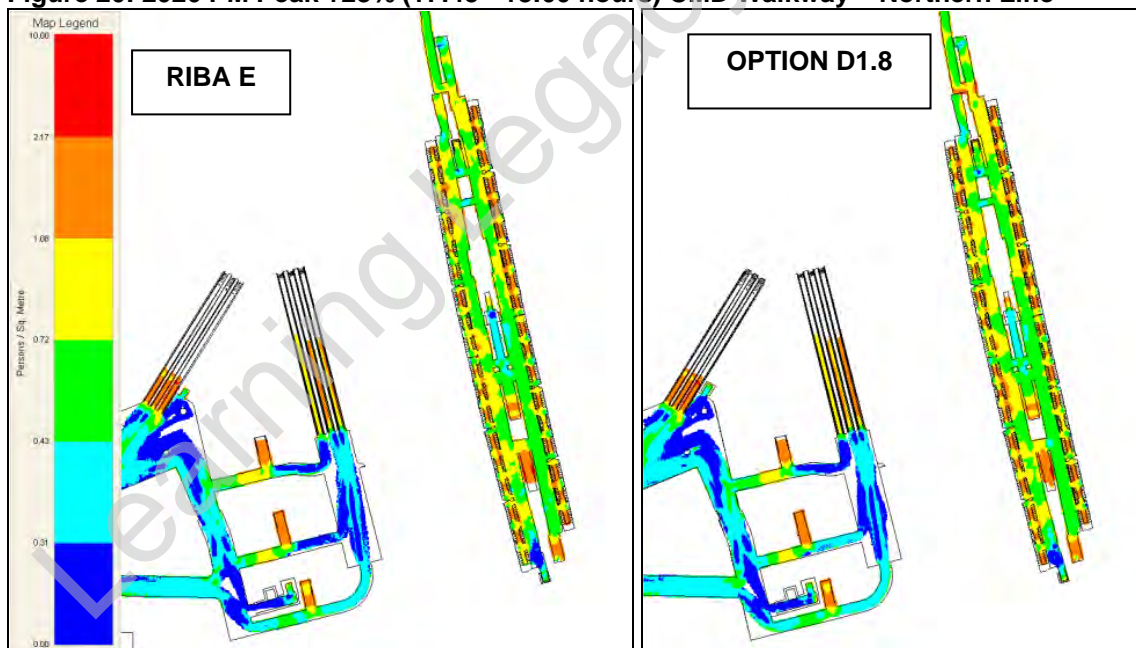
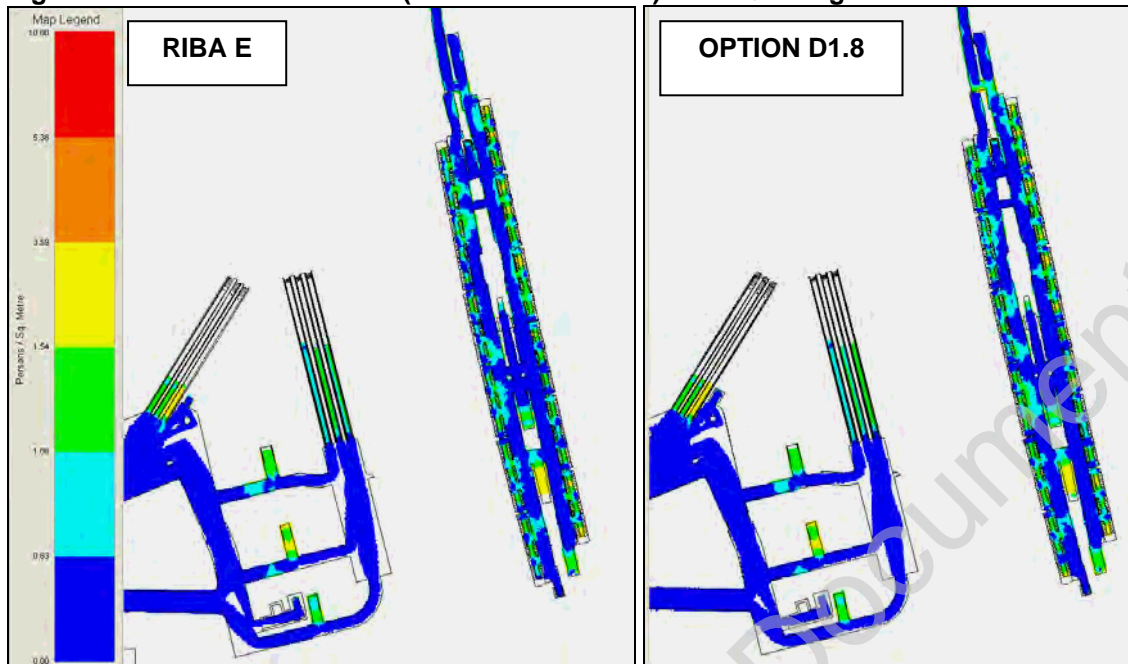

Figure 21: 2026 PM Peak +28% (17:45 - 18:00 hours) CMD Queuing – Northern Line



Key inferences from these maps are as below:

1. CMD and CHD maps for RIBA E and Option D1.8 show no significant difference in the results between the two schemes;
2. The density maps show that the Northern Line platforms perform predominantly at Walkway LoS C with small areas of LoS D. However, the density maps for Queuing predominantly show LoS A (Queuing LoS B is LU's acceptance criteria for platforms); and
3. The proposed three Northern Line stairs show some level of congestion for the two demand scenarios modelled in both the schemes (RIBA E and Option D1.8). However, this congestion clears relatively quickly between the train headways without causing major disruption to the rest of the station.

7.3 Western Ticket Hall

Figure 22 shows the Cumulative Mean Density (CMD) maps for Walkways for the Western Ticket Hall for AM Peak 15 minutes for the +28% demand scenario.

CMD maps for Stairways are included in Appendix C.

CHD maps are included in Appendices D and E.

7.3.1 AM Peak

Figure 22: 2026 AM Peak +28% (08:45 - 09:00 hours) CMD Walkway - Western Ticket Hall

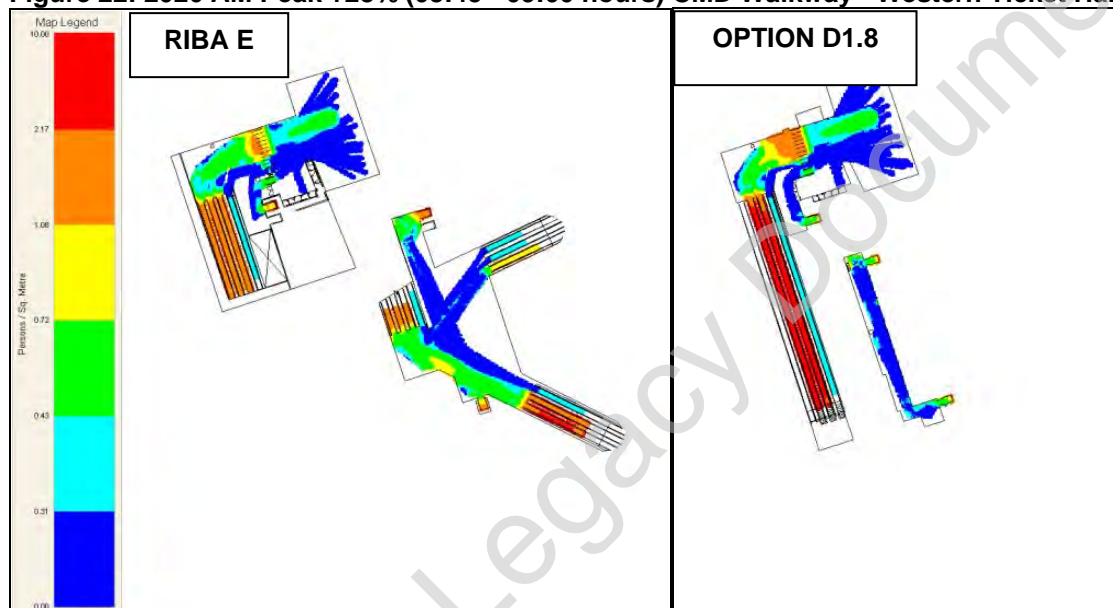

The results are as below:

1. Congestion was observed at the gateline of the Western TH resulting from the additional 3,150 passengers in the matrices;
2. The seven exit gates show Walkway level of service D, while predominantly level of service B in front of the entry gates and WAGs. However, the overall results show that the nine ticket gates proposed have sufficient capacity to cater for passengers entering/exiting the Western TH during the AM peak period for the 2026 +28% demand levels without compromising the safety of the passengers; and
3. The results show that the lifts have sufficient capacity to cater for the peak demand.

7.3.2 PM Peak

The PM Peak results for Western Ticket Hall is shown in **Figures 23**. It was observed that the overall Level of Service experienced by passengers at the gateline was within the acceptable limits of Walkway Level of Service C resulting from a more balanced entry / exit flows in the PM peak period.

Figure 23: 2026 PM Peak +28% (17:45 - 18:00 hours) CMD Walkway - Western Ticket Hall

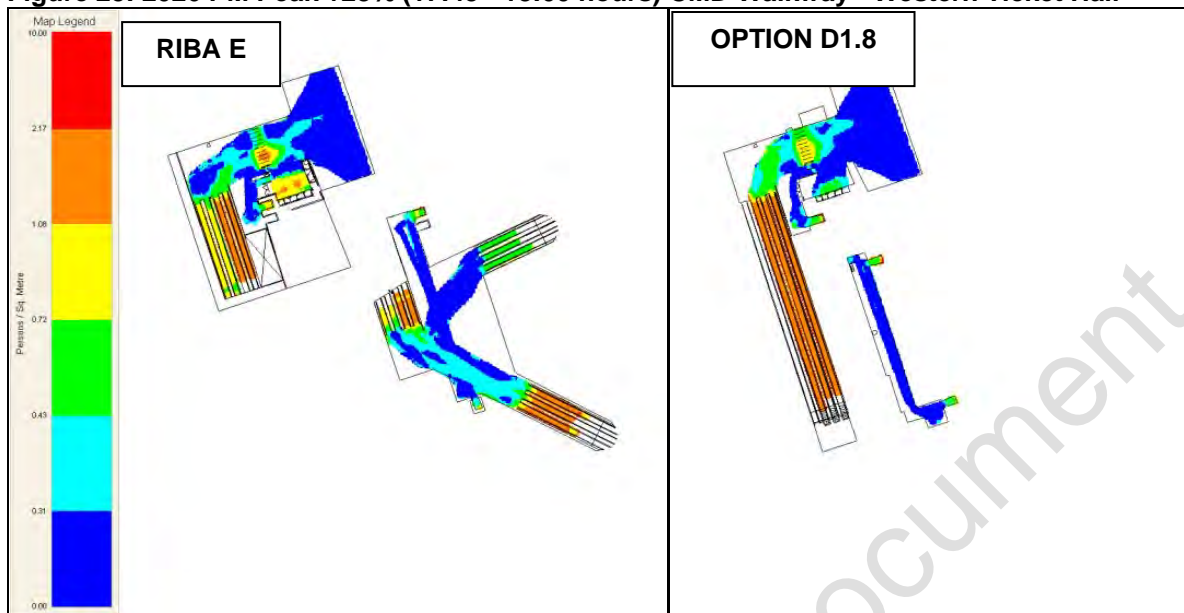
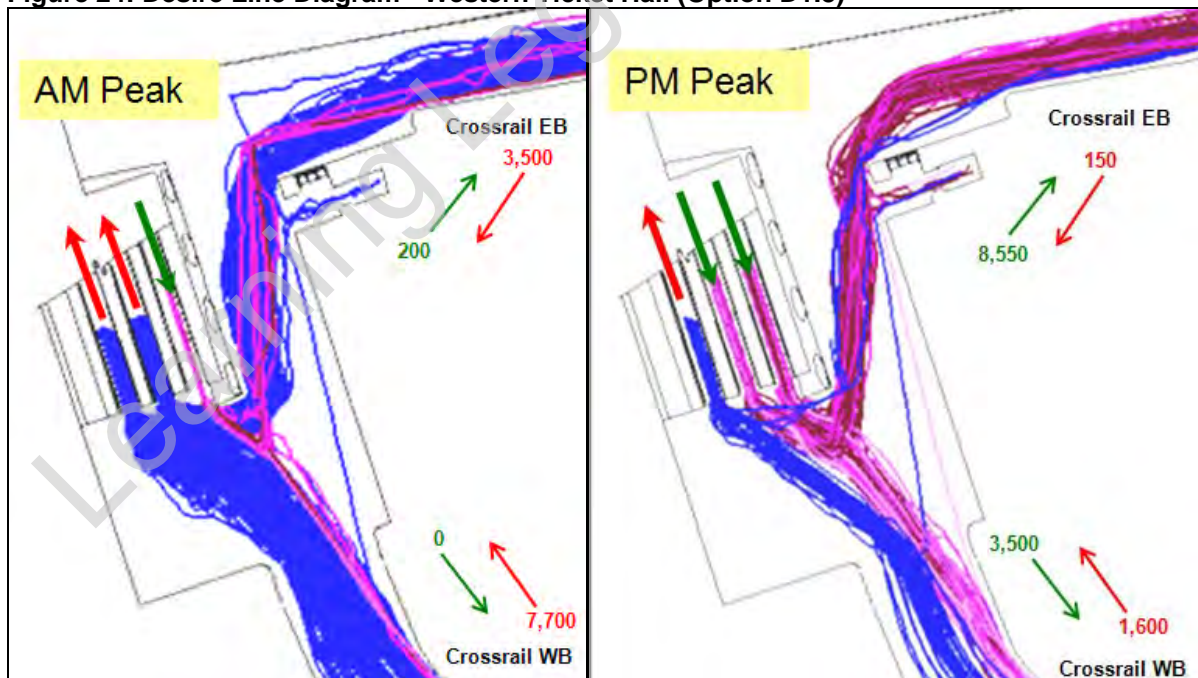

Figure 24 shows the desire line diagram for Crossrail’s western concourse. The escalator configurations have been optimised to reduce crossflows at the foot of the escalators. Passenger management such as a temporary barrier in the peak periods is recommended at the foot of the escalators to separate the entry/exit flows in order to improve circulation in the lower concourse.

Figure 24: Desire Line Diagram - Western Ticket Hall (Option D1.8)



7.4 Eastern Ticket Hall

7.4.1 AM Peak

Figure 25: 2026 AM Peak +28% (08:45 - 09:00 hours) CMD Walkway – Eastern Ticket Hall

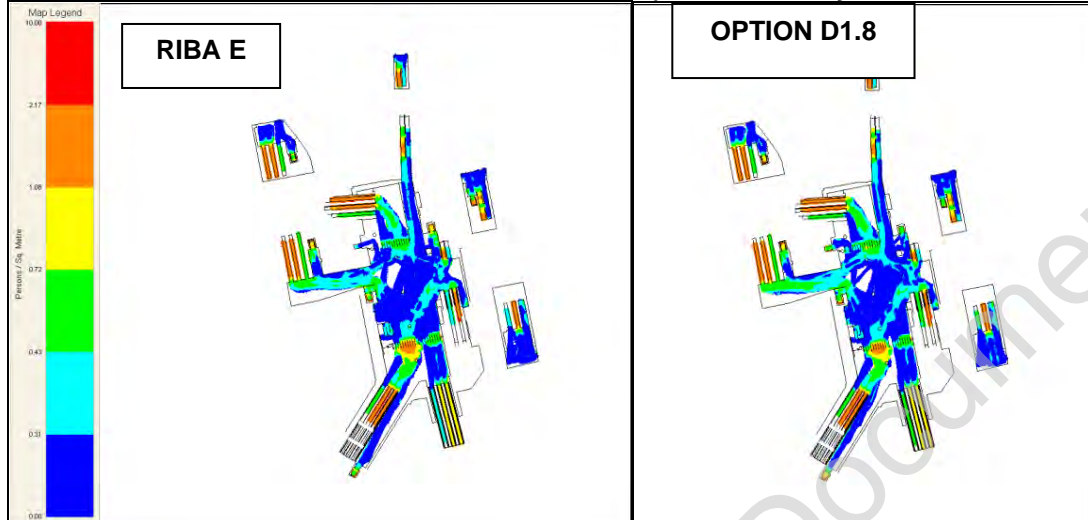

7.4.1 PM Peak

Figure 26: 2026 PM Peak +28% (17:45 - 18:00 hours) CMD Walkway – Eastern Ticket Hall

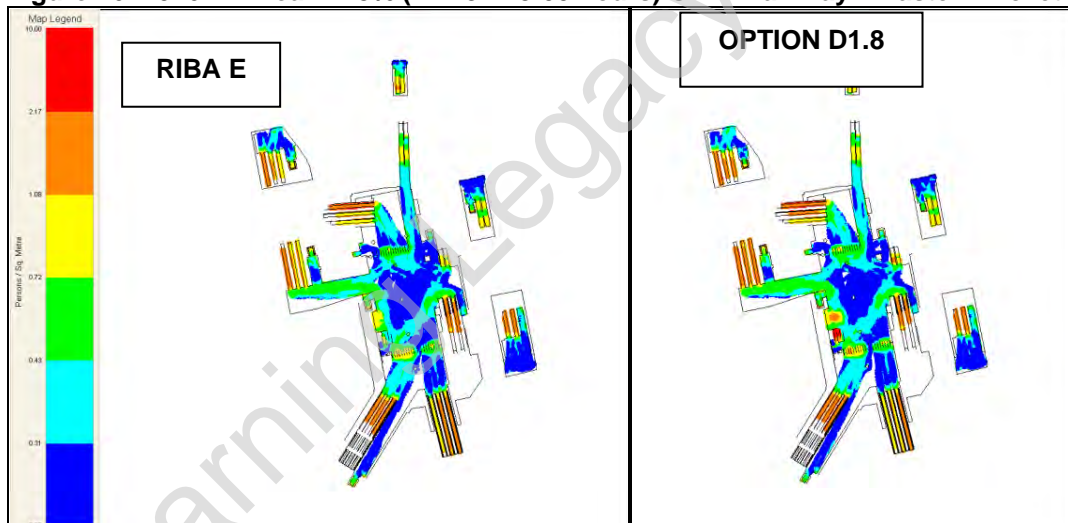

The results for Eastern TH are as below:

1. The cumulative mean density maps for the AM and PM peak 15 minutes (**Figure 25 and 26**) predominantly shows LoS A and B during the AM Peak period in the Eastern TH;
2. No queuing is observed at the escalators or stairways. From the passenger density maps it was observed that the gateline and vertical circulation elements have sufficient capacity to cater for the additional Central Line passengers re-routed from the Western Ticket Hall; and
3. The outbound gateline adjacent to the Crossrail's escalators shows Level of Service D/E in the AM peak, while predominantly Level of Service B at the remaining gates and WAGs. It was observed that, overall, the 16 ticket gates and 2 WAGs at the Crossrail end of the ticket hall have sufficient capacity to cater for passengers entering/exiting the ticket hall during the AM peak period for 2026 +28% demand level.

7.5 Crossrail Platform Level

Figure 27 shows the Legion modelling results for the Crossrail Platforms, concourse and passageways for AM peak 15 minutes for the two schemes.

CMD maps for Stairways are included in Appendix C.

CHD maps are included in Appendices D and E.

Figure 27: 2026 AM Peak +28% (08:45 - 09:00 hours) CMD Walkway – Crossrail Platforms

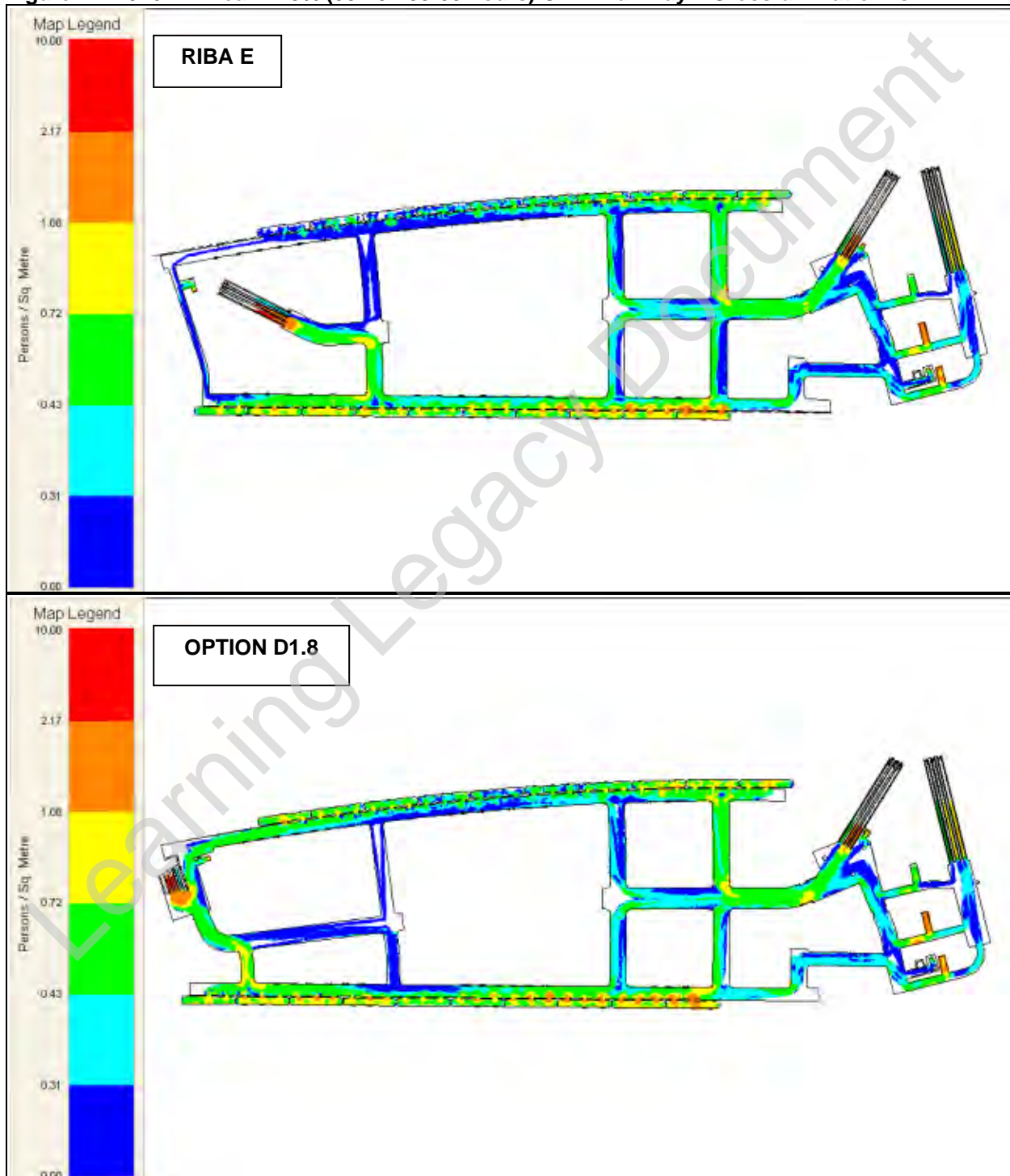

Key inferences from the passenger density maps are as follows:

1. The cumulative mean density maps show that 4.5m wide Crossrail platforms function satisfactorily during the AM Peak for the 2026 +28% demand level. The mean density maps for queuing (LU's criteria for acceptability) show LoS A all along the Crossrail platforms;
2. The areas in front of platform edge doors (PEDs) reach Level of Service D or E. Passengers are expected to crowd around the PEDs irrespective of the overall queuing space available on the platforms;
3. The adits perform satisfactorily and the overall Walkway Levels of Service does not exceed level C. However, it was observed that a small area within the western most adit from the westbound platform shows Walkway LoS D in the 2026AM +28% scenario resulting from heavy flow of passengers from the initial four carriages of the westbound train. However, the CHD maps shows that the density level exceeds the threshold of Walkway LoS C for less than two minutes only following a cancelled train service;
4. The Crossrail's Central Concourse shows small pockets of congestion but generally has adequate capacity to accommodate passengers at 2026 +28% demand level;
5. The escalators connecting to the Eastern TH have sufficient capacity to cater for peak passenger demand; and
6. The modelling results show that the escalators connecting to the Western Ticket Hall have sufficient capacity to cater for the peak passenger flows. Although, queuing was observed at the bottom of the escalators, it was observed to clear between the train headways.

7.5.1 PM Peak

Results from the PM Peak models show that the Crossrail platforms, adits, central concourse and the escalators have sufficient capacity to accommodate the passengers at 2026 +28% demand level as shown in **Figure 28**.

Figure 28: 2026 PM Peak +28% (17:45 - 18:00 hours) CMD Walkway – Crossrail Platforms

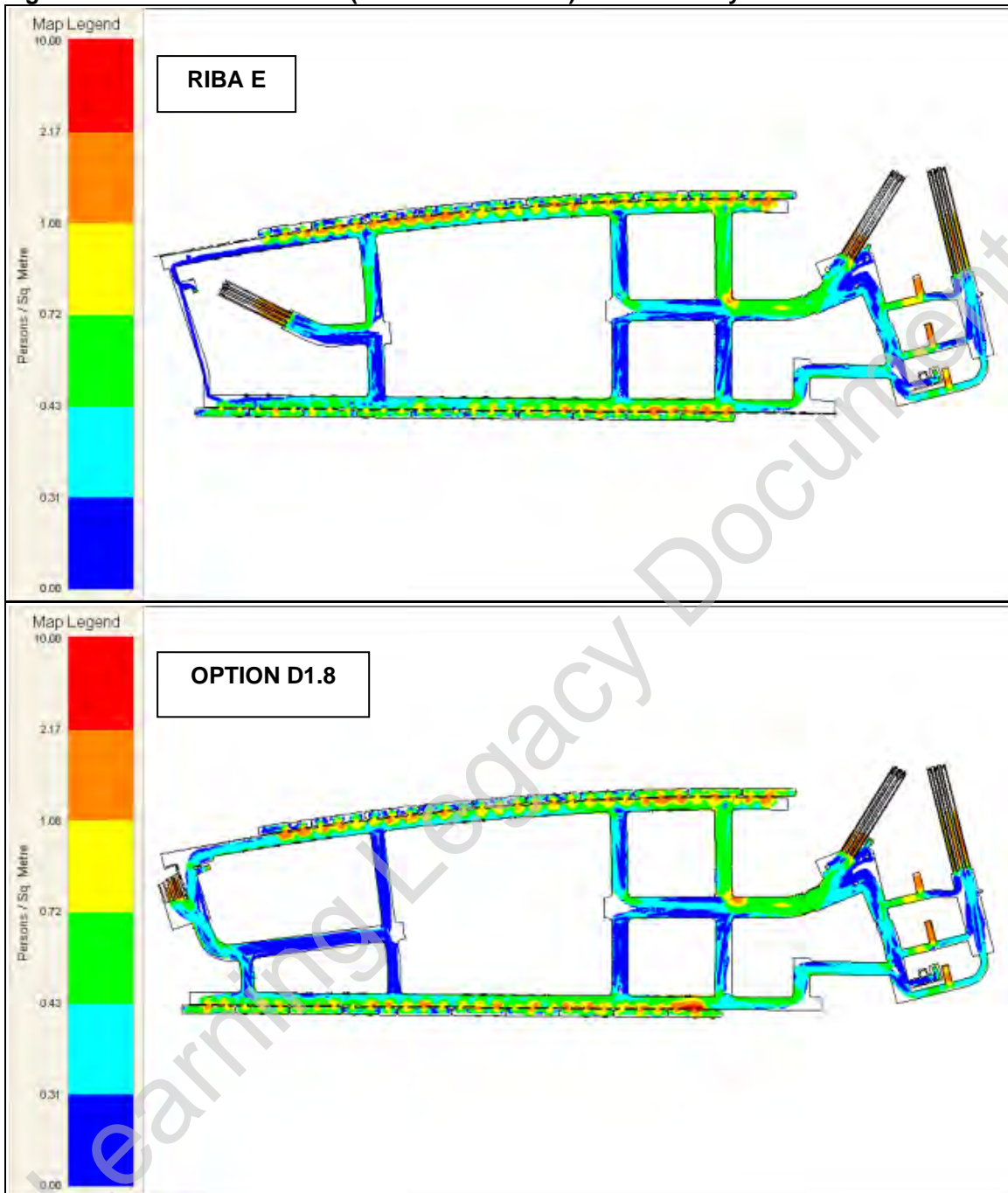

8 Summary and Conclusions

This report summarises the modelling inputs, assumptions and results from the Legion modelling study of C134's Option D1.8 at Tottenham Court Road station.

The results from Legion modelling showed that the pedestrian areas within the proposed station complex generally satisfy Level of Service (LoS) criteria defined within the LU's 1-371 and Crossrail's Pedestrian Modelling Guidelines (CR/QMS/OPS/GN/0010).

In summary, the following points are noted:

1. Passenger density plots for the Eastern Ticket Hall do not show any significant congestion during the morning and evening peak periods. The escalators, stairways and ticket gates have sufficient capacity to cater for peak passenger flows at up to 2026 +28% demand levels and also including the additional Central Line passengers re-routed from the western entrance;
2. The cumulative mean density maps show that the Crossrail platforms and the passageways to/from the platforms are adequately designed and sized to accommodate up to 2026 +28% passenger demand levels;
3. However, it was observed that a small area within the western most adit from the westbound platform shows Walkway LoS D in the 2026 AM+28% scenario resulting from heavy flow of passengers from the initial four carriages of the westbound train. However, the CHD maps shows that the density level exceeds the threshold of Walkway LoS C for less than two minutes only following a cancelled train service;
4. The Northern Line platforms operate at acceptable levels of service. Some intermittent congestion was observed on the middle stairs within the LU's TCR upgrade scheme, which relatively clears in a short period without causing major operational disruptions to the rest of the station;
5. No significant difference was observed on the passenger levels of service within the Central Line Concourse and Central Line Platform; and
6. Congestion was observed at the outbound gates within the Western TH and at the foot of the escalators in the western concourse resulting from the additional 3,150 passengers (Crossrail EB to Western TH) in the AM peak. Passenger management such as a temporary barrier in the peak periods is recommended at the foot of the escalators to separate the entry/exit flows in order to improve circulation in the western concourse.

In general, it was observed that the Project Assure proposal of omitting the Central Line Link from Western Ticket Hall has no significant impact on the Eastern Ticket Hall and the Central Line concourse. The density maps showed that the passenger levels of service are within the LU/CRL acceptable limits.

No change in passenger level of service (compared with the RIBA E design) was observed in the Northern Line platforms and within the TCR LU upgrade scheme.

9 Reference Documents

Business Case Development Manual (BCDM), TfL, May 2008

Crossrail Programme Functional Requirements v4.1, CR/QMS/DEV/P/0117

Crossrail's Pedestrian Modelling Guidelines (CR/QMS/OPS/GN/0010)

Crossrail's Pedestrian Modelling Standard, Station Planning: Platforms (CR-STD-305, V6)

LU's Standard 1-371 Station Planning, August 2009

LU's Station modelling with Legion Best Practice Guide v2, July 2009

Mobility Impaired Passengers an Army Ignored, LUL, November 2007

Learning Legacy Document

10 Appendix A: Option D1.8 Adjusted 2026 Demand Note from CRL [REDACTED]

TCR 2026 demand

Proposal 1

This is based on Railplan XR153 and is a modified version of that in CPFRv5. To account for link deletion the Central line to Dean St passengers are moved to the east entrance. In addition three thousand passengers are added to Dean St due to the excess variation in flows from the two Crossrail platforms.

This option does not follow the usual forecasting procedures. This forecast has only been used as an additional test on option D1.

However:

- This forecast does not account for the impact of passenger re-distribution resulting from deletion of the Central line link.
- There is a known error in the PM matrix (which only impacts LUL areas of the station).
- The additional 3,000 passengers at Dean Street are justified by the 350 modelled WB flow being “unreasonably low”.

It is this proposal on which it is proposed to test option D1.8 for Sponsor Affirmation. Although it does not follow normal Railplan methodology, it will provide an immediate “stress test” to the station, and will allow an immediate view on whether the station will function in a worst case.

2026 With Crossrail - AM Peak Period Demand at Tottenham Court Road									
TCR XR153 RuAM	T C R EASTERN SE	T C R DEAN ST SE	T C R NORTHERN (NB)	T C R NORTHERN (SB)	T C R CENTRAL (EB)	T C R CENTRAL (WB)	T C R CROSSRAIL (EB)	T C R CROSSRAIL (WB)	TOTAL
T C R EASTERN SE	-	-	250	300	450	300	500	350	2150
T C R DEAN ST SE	-	-	-	-	-	-	200	0	200
T C R NORTHERN (NB)	3400	-	-	-	1050	400	650	450	5950
T C R NORTHERN (SB)	1900	-	-	-	2550	1950	2900	1800	11100
T C R CENTRAL (EB)	2400	-	750	250	-	-	-	-	3400
T C R CENTRAL (WB)	4000	-	850	0	-	-	-	-	4850
T C R CROSSRAIL (EB)	2600	3500	1300	800	-	-	-	-	8200
T C R CROSSRAIL (WB)	5800	7700	750	1800	-	-	-	-	16050
TOTAL	20100	11200	3900	3150	4050	2650	4250	2600	51900

2026 With Crossrail - PM Peak Period Demand at Tottenham Court Road									
TCR XR153 RuPM	T C R EASTERN SE	T C R DEAN ST SE	T C R NORTHERN (NB)	T C R NORTHERN (SB)	T C R CENTRAL (EB)	T C R CENTRAL (WB)	T C R CROSSRAIL (EB)	T C R CROSSRAIL (WB)	TOTAL
T C R EASTERN SE	-	-	2700	1500	3050	3200	6450	2900	19800
T C R DEAN ST SE	-	-	-	-	-	-	8550	3500	12050
T C R NORTHERN (NB)	2800	-	-	-	0	550	2400	1050	6800
T C R NORTHERN (SB)	3650	-	-	-	1600	1200	1000	1750	9200
T C R CENTRAL (EB)	2900	-	2250	1250	-	-	-	-	6400
T C R CENTRAL (WB)	2850	-	2100	1950	-	-	-	-	6900
T C R CROSSRAIL (EB)	2450	150	2400	600	-	-	-	-	5600
T C R CROSSRAIL (WB)	3650	1600	3850	850	-	-	-	-	9950
TOTAL	18300	1750	13300	6150	4650	4950	18400	9200	76700

11 Appendix B: Peak 15 minutes Cumulative Mean Density (CMD) Maps – Queuing Levels of Service

11.1 2026 AM Peak +28%

Figure 29: 2026 AM Peak +28% (08:45 - 09:00 hours) CMD Queuing – Northern Line

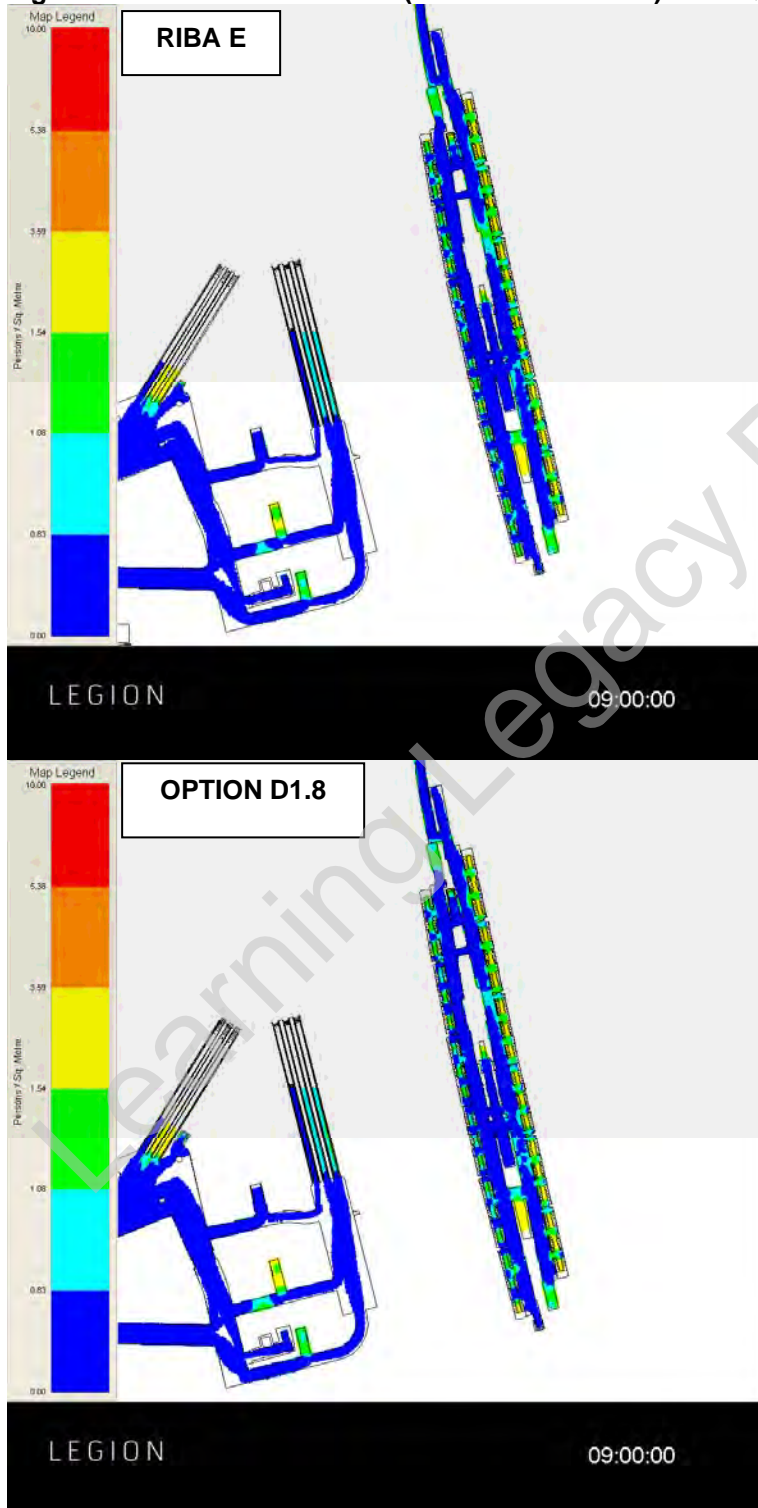

Figure 30: 2026 AM Peak +28% (08:45 - 09:00 hours) CMD Queuing - Crossrail

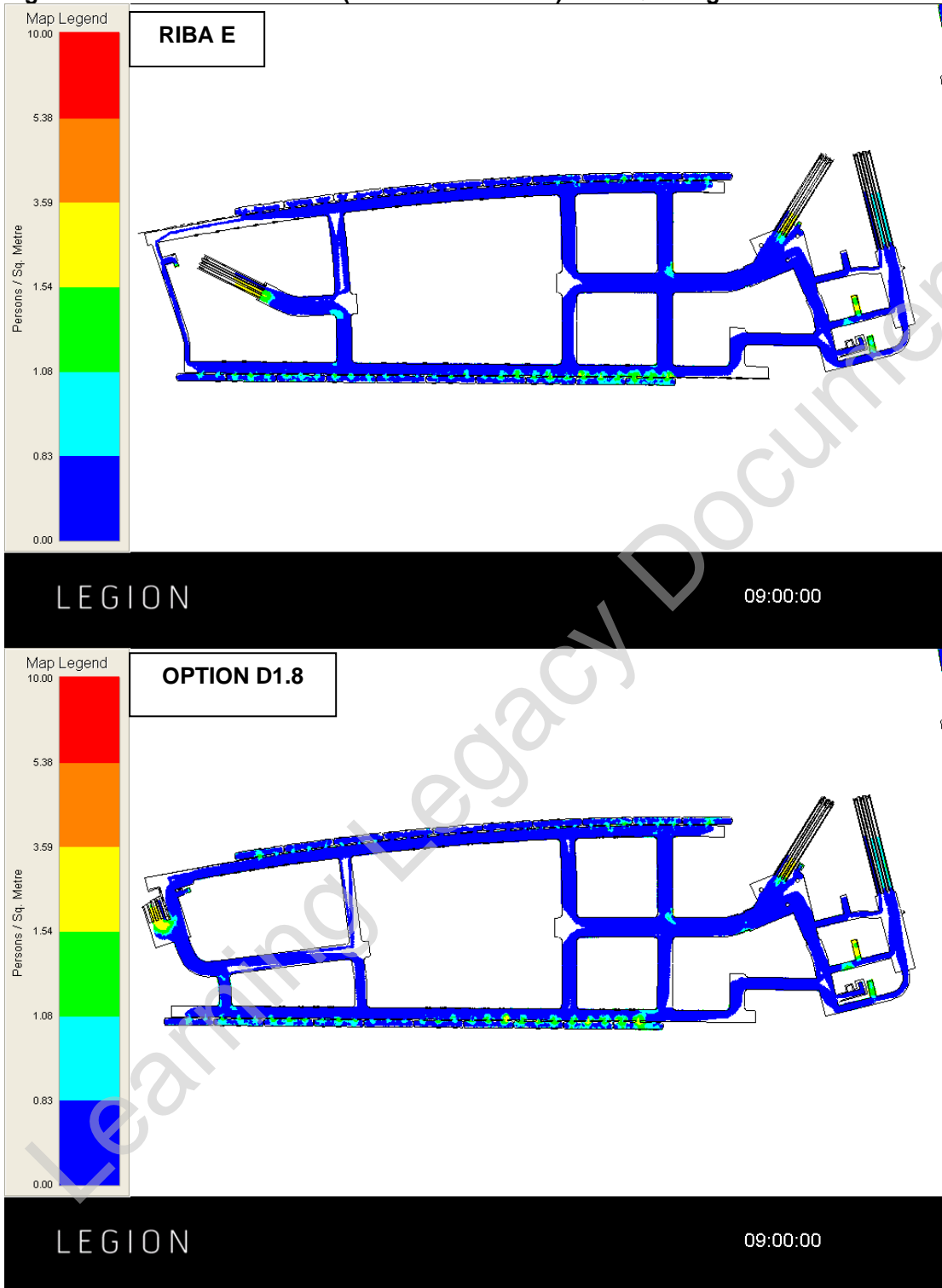

Figure 31: 2026 AM Peak +28% (08:45 - 09:00 hours) CMD Queuing – Western Ticket Hall



Figure 32: 2026 AM Peak +28% (08:45 - 09:00 hours) CMD Queuing – Central Line



Figure 33: 2026 AM Peak +28% (08:45 - 09:00 hours) CMD Queuing – Eastern Ticket Hall



11.2 2026 PM Peak +28%

Figure 34: 2026 PM Peak +28% (17:45 - 18:00 hours) CMD Queuing – Northern Line

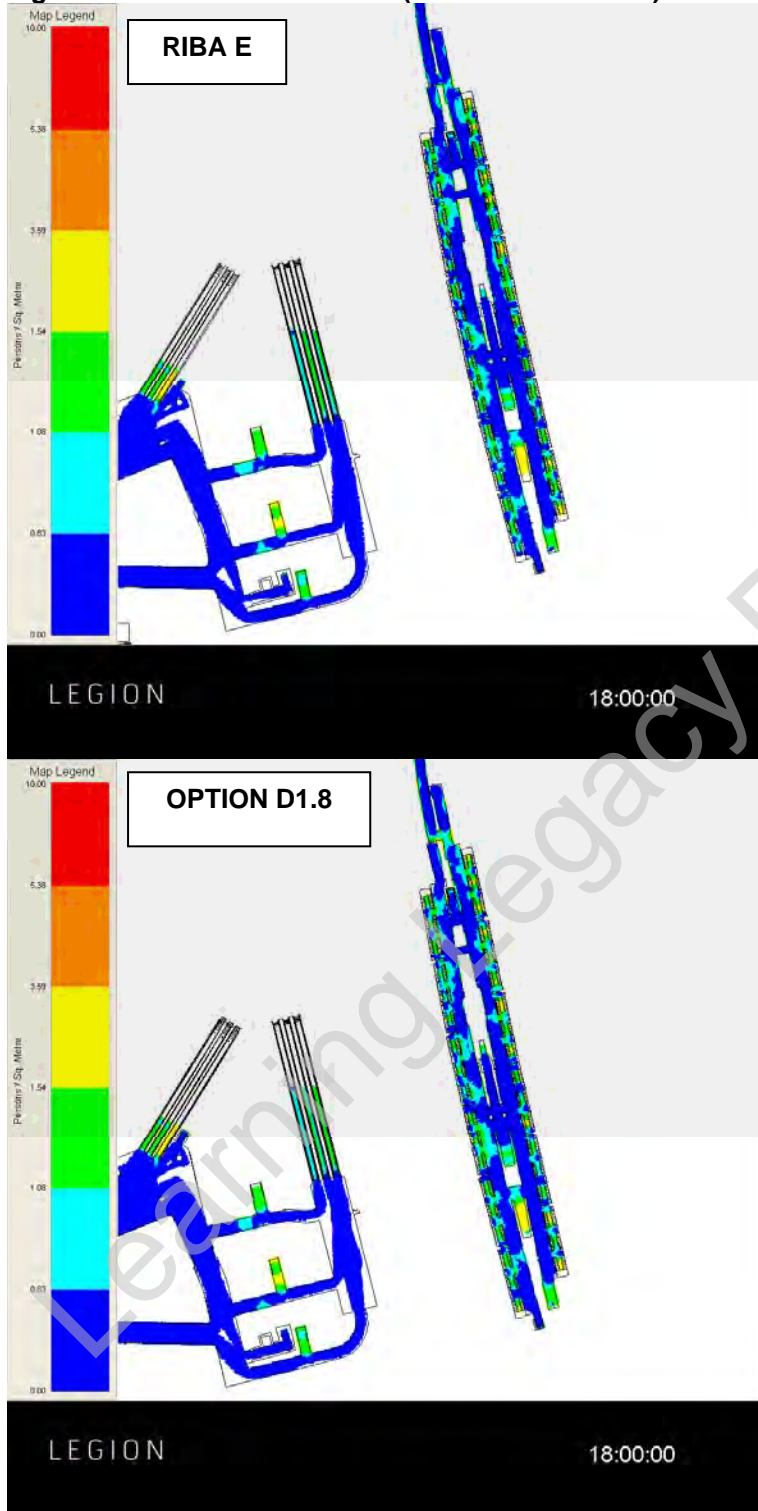

Figure 35: 2026 PM Peak +28% (17:45 - 18:00 hours) CMD Queuing - Crossrail

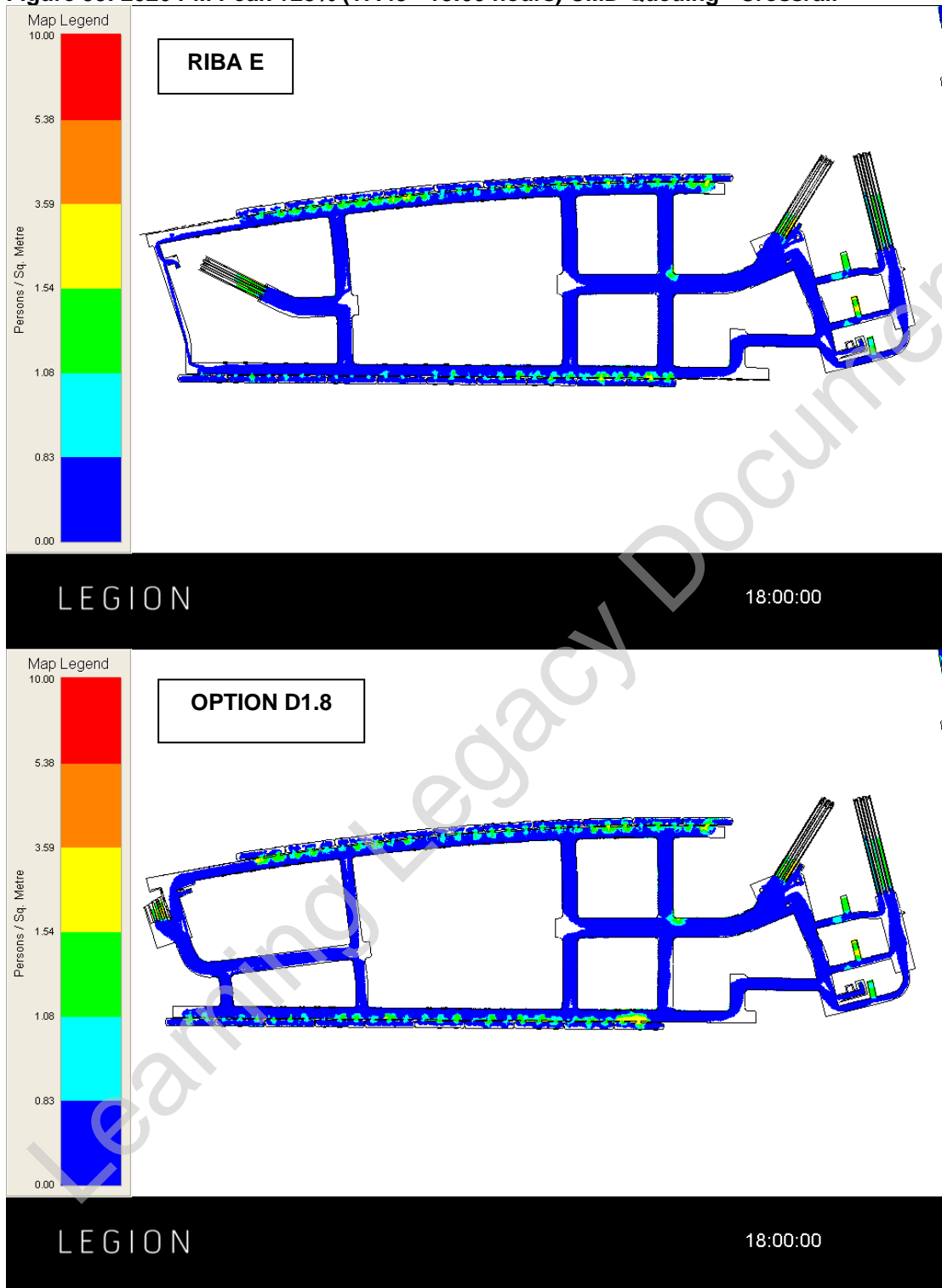

Figure 36: 2026 PM Peak +28% (17:45 - 18:00 hours) CMD Queuing – Western Ticket Hall

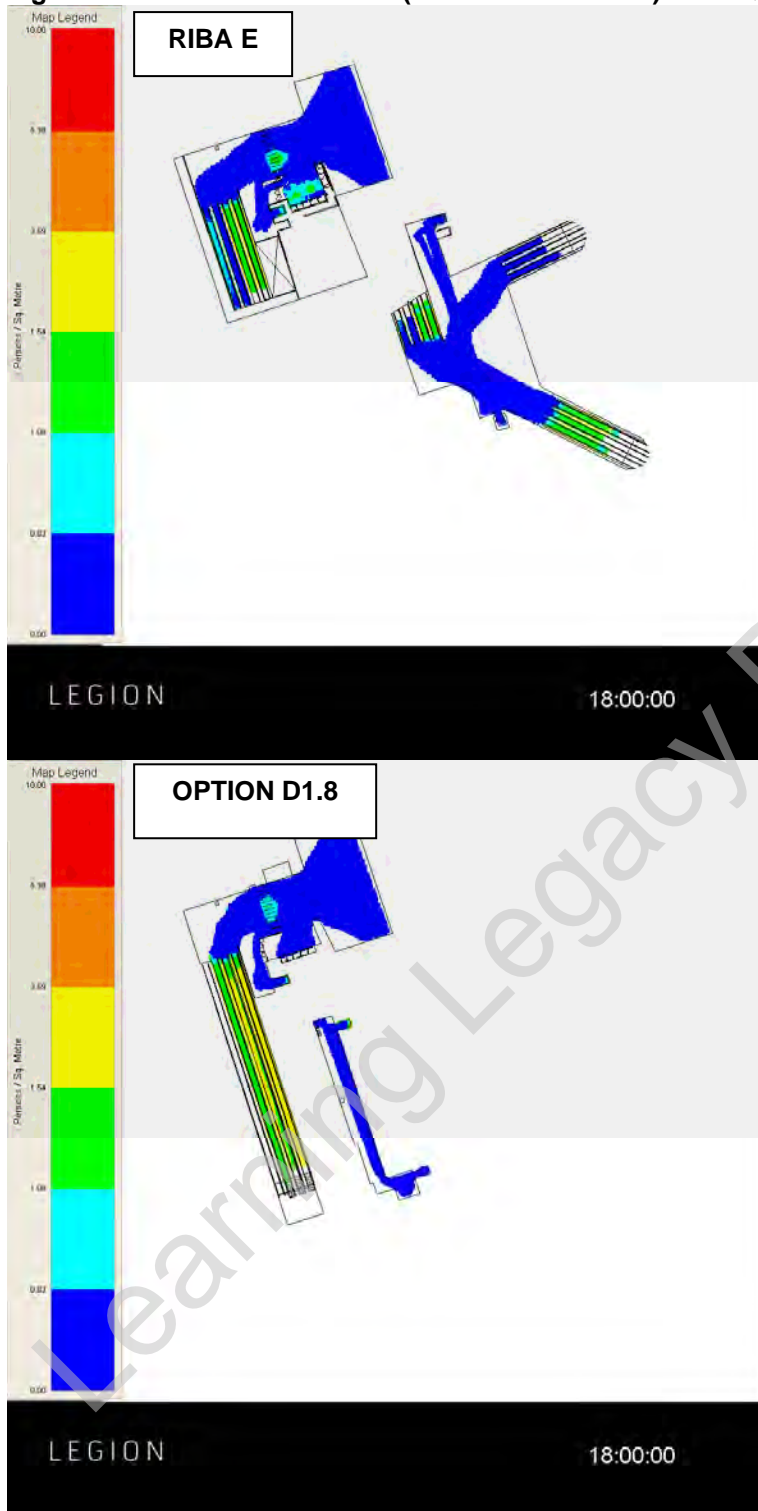
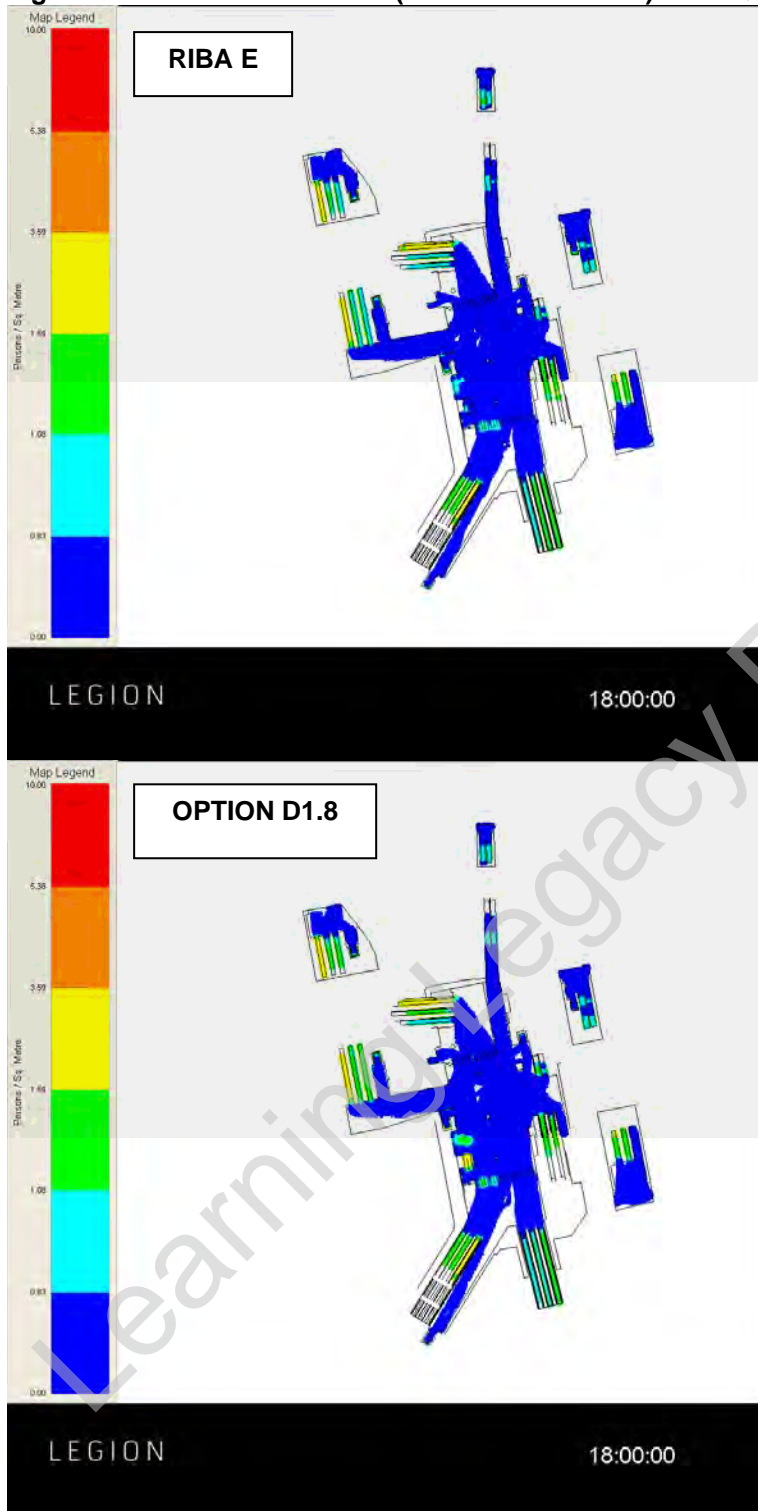

Figure 37: 2026 PM Peak +28% (17:45 - 18:00 hours) CMD Queuing – Central Line



Figure 38: 2026 PM Peak +28%(17:45 - 18:00 hours) CMD Queuing – Eastern Ticket Hall



12 Appendix C: Peak 15 minutes Cumulative Mean Density (CMD) Maps – Staircase Levels of Service

12.1 2026 AM Peak +28%

Figure 39: 2026 AM Peak +28% (08:45 - 09:00 hours) CMD Staircase – Northern Line

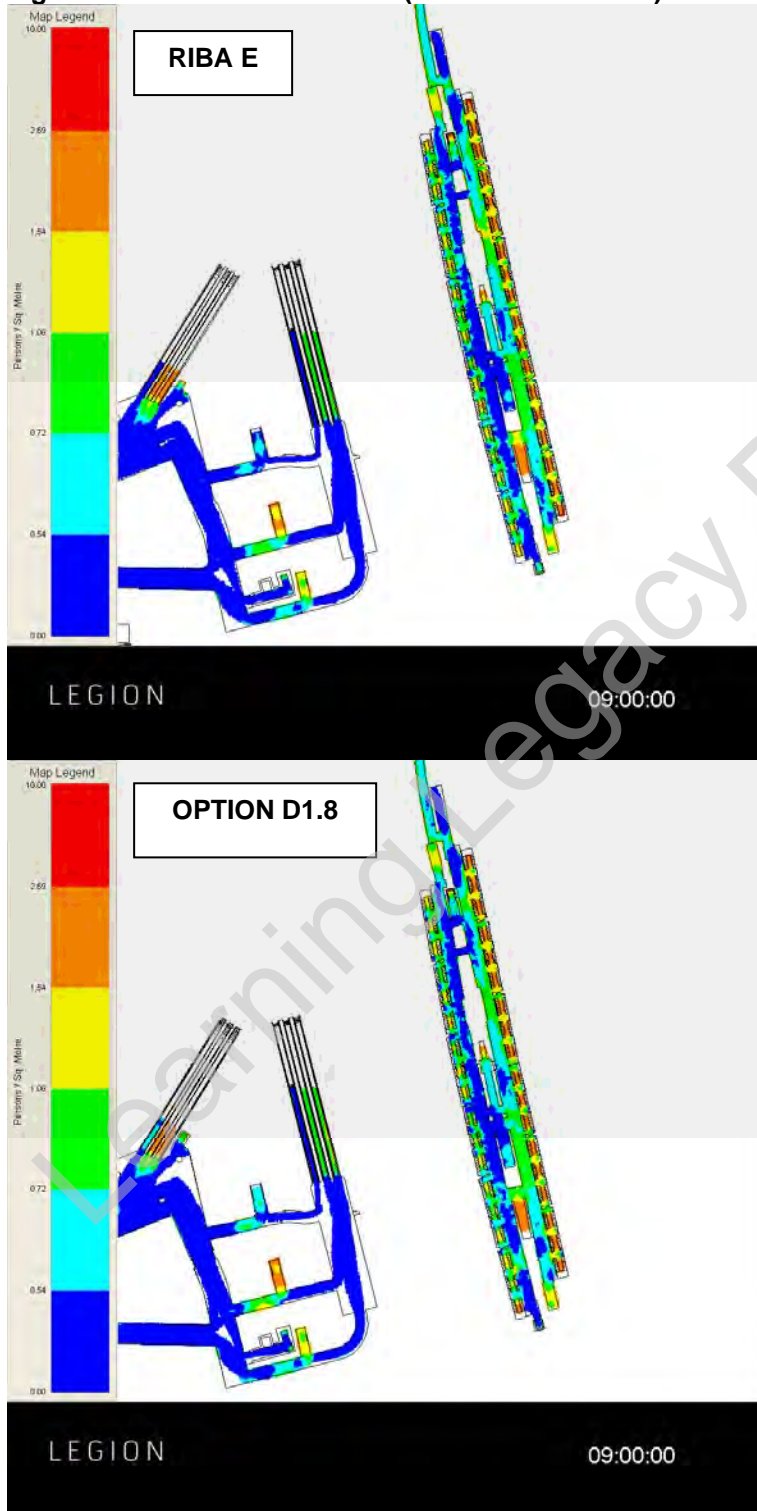

Figure 40: 2026 AM Peak +28% (08:45 - 09:00 hours) CMD Staircase – Central Line

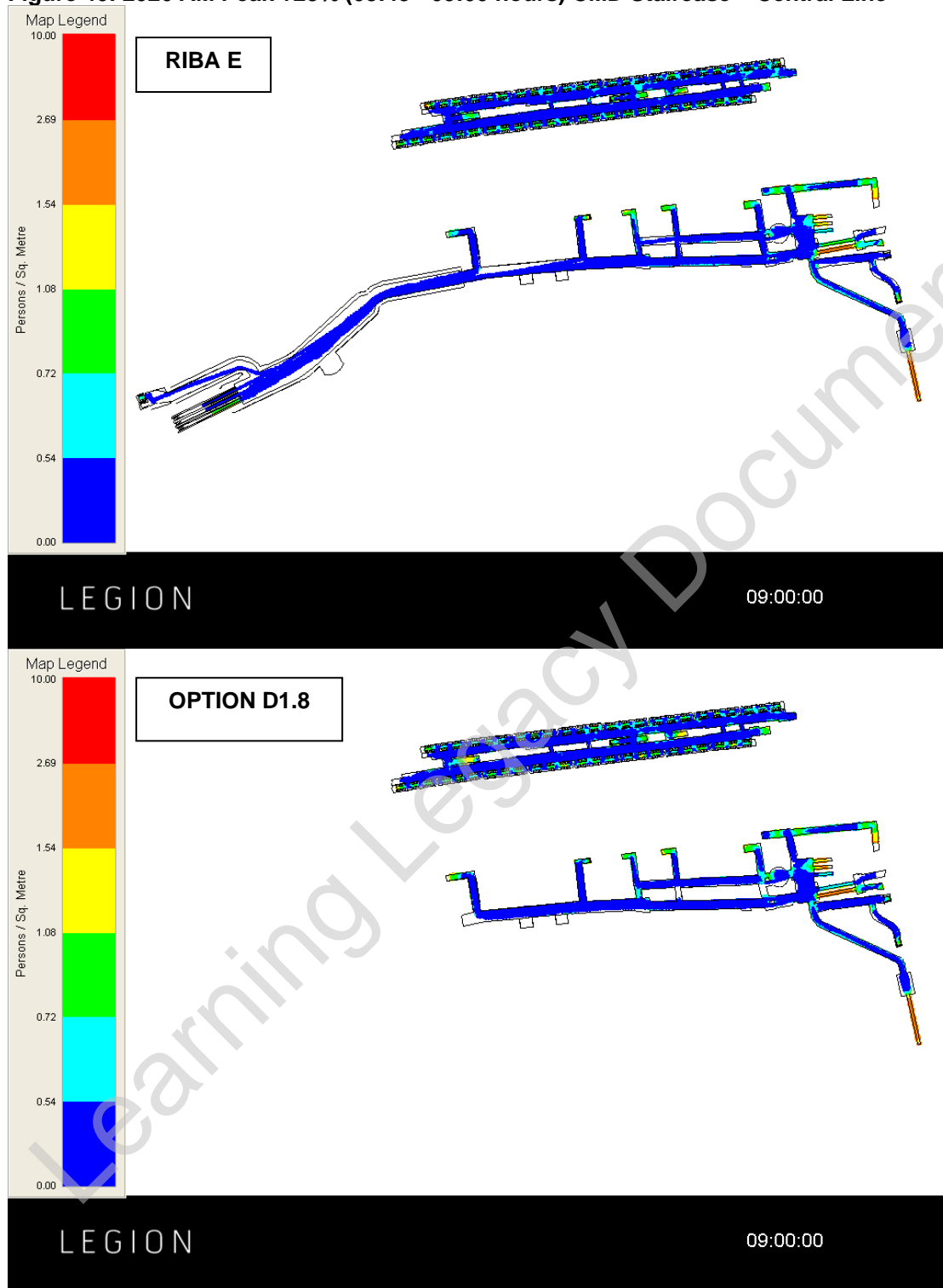

Figure 41: 2026 AM Peak +28% (08:45 - 09:00 hours) CMD Staircase – Eastern Ticket Hall



12.2 2026 PM Peak +28%

Figure 42: 2026 PM Peak +28% (17:45 - 18:00 hours) CMD Staircase – Northern Line

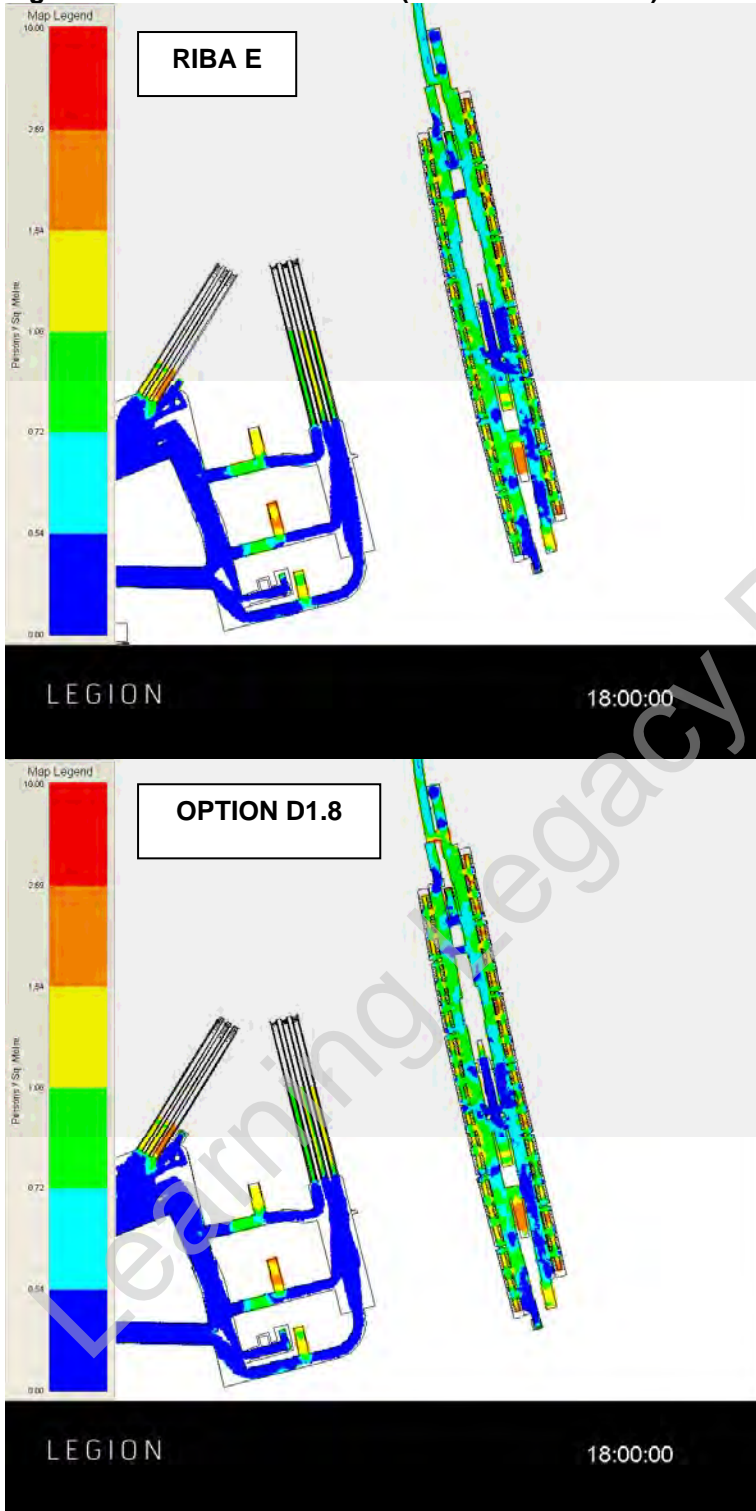
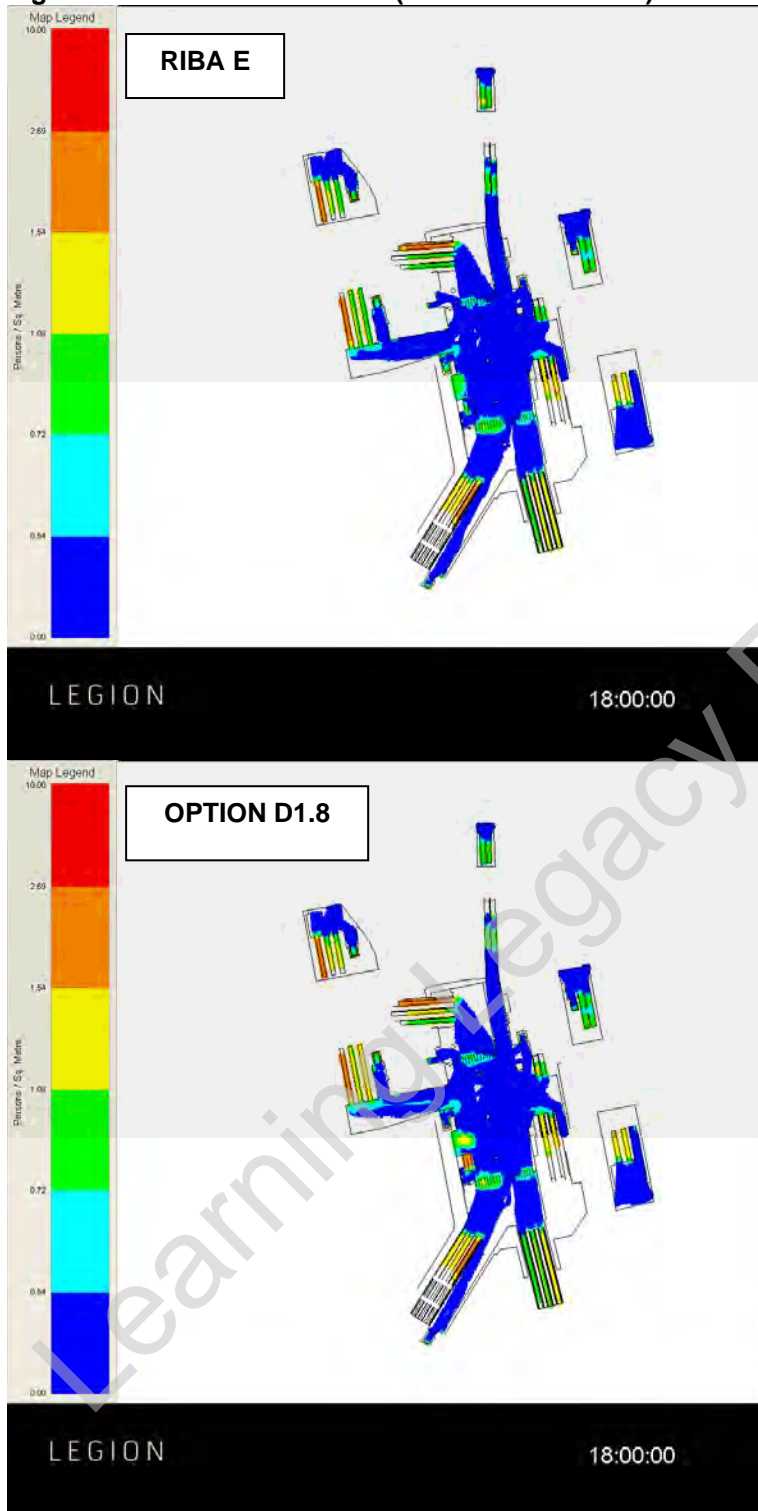

Figure 43: 2026 PM Peak +28% (17:45 - 18:00 hours) CMD Staircase – Central Line



Figure 44: 2026 PM Peak +28%(17:45 - 18:00 hours) CMD Staircase – Eastern Ticket Hall



13 Appendix D: Peak 15 minutes Cumulative High Density (CHD) Maps – 1.08 passengers/m²

13.1 2026 AM Peak +28%

Figure 45: 2026 AM Peak +28% (08:45 - 09:00 hours) CHD 1.08 passengers/m² – Northern Line

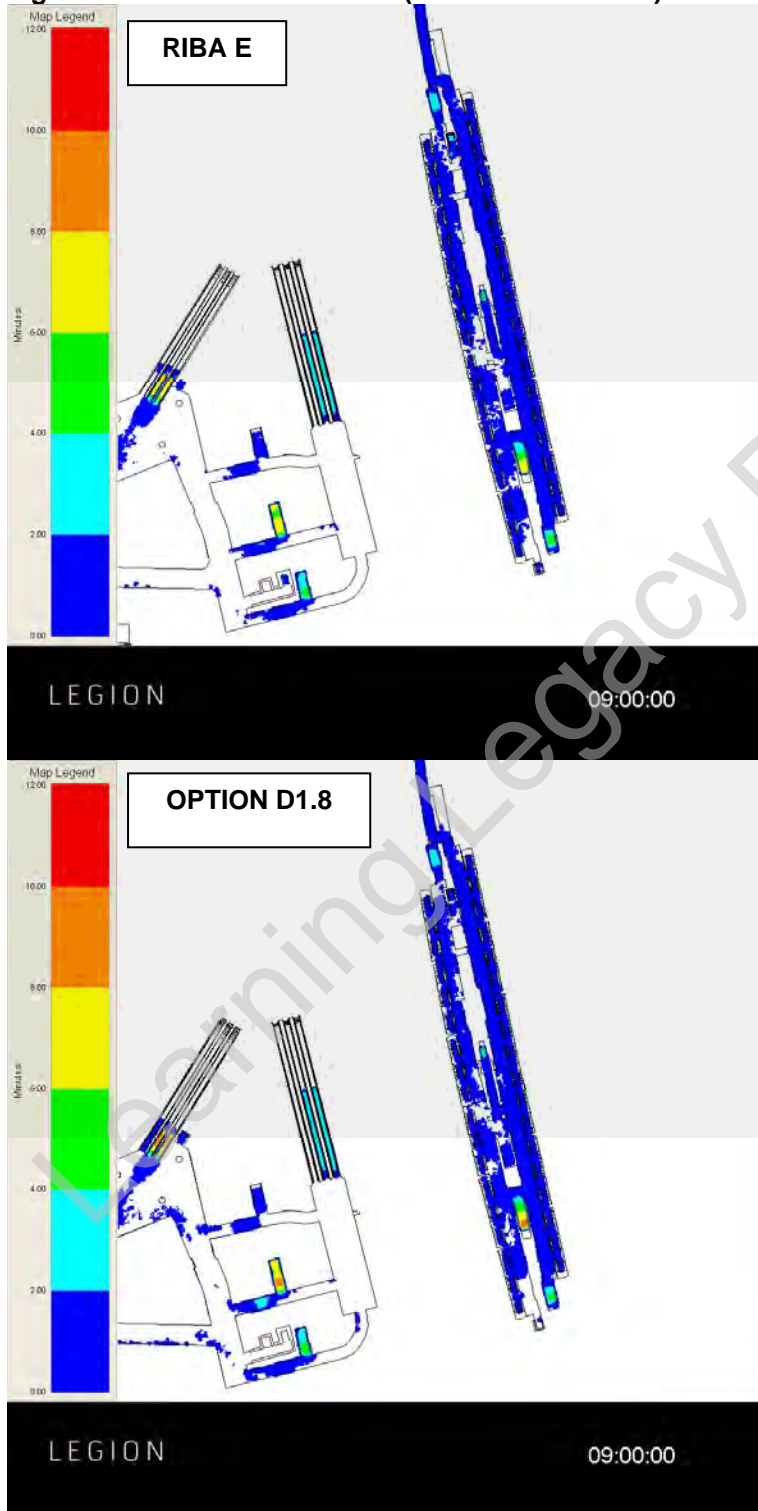

Figure 46: 2026 AM Peak +28% (08:45 - 09:00 hours) CHD 1.08 passengers/m² - Crossrail

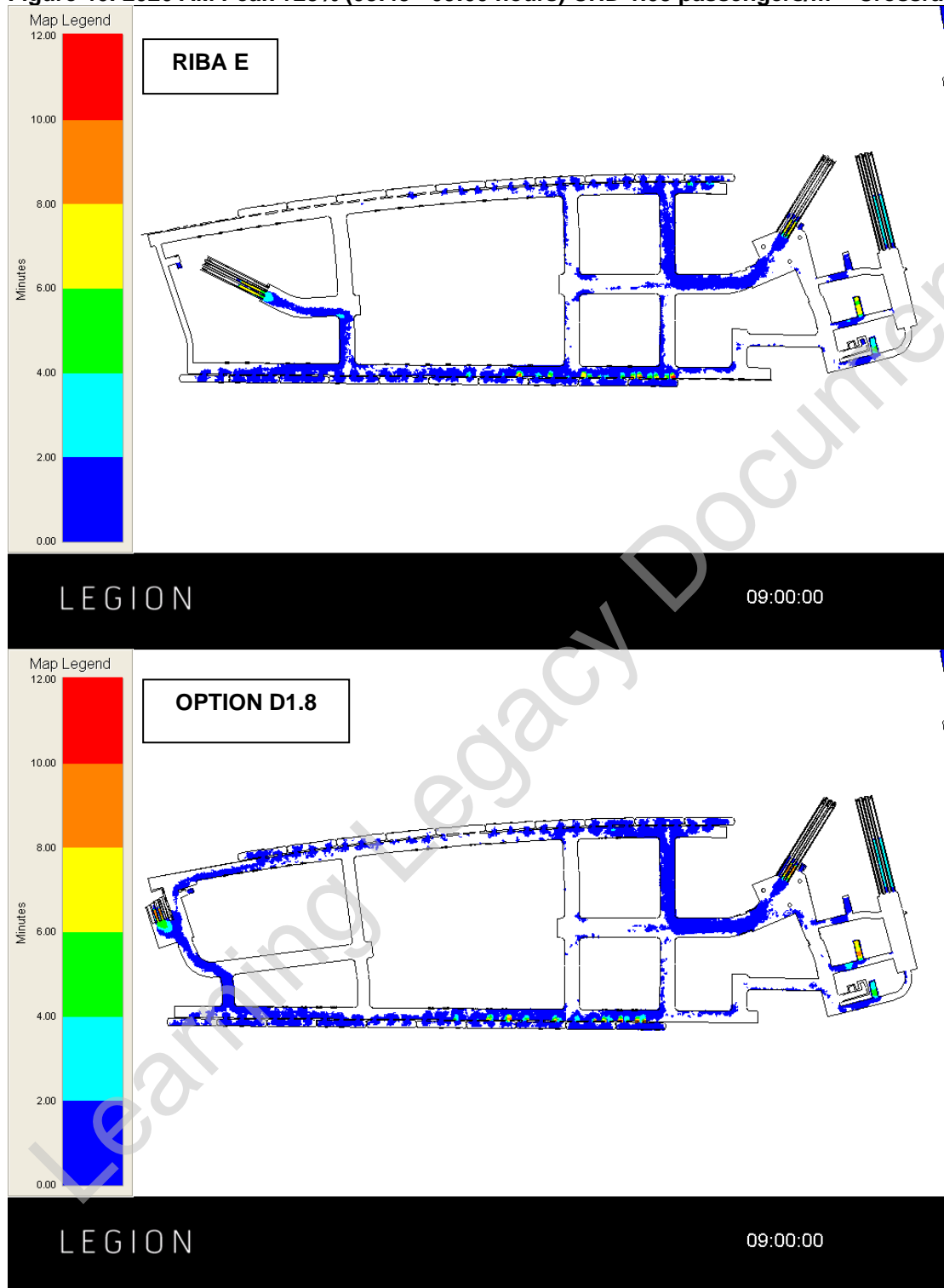

Figure 47: 2026 AM Peak +28% (08:45 - 09:00 hours) CHD 1.08 passengers/m² – Western Ticket Hall

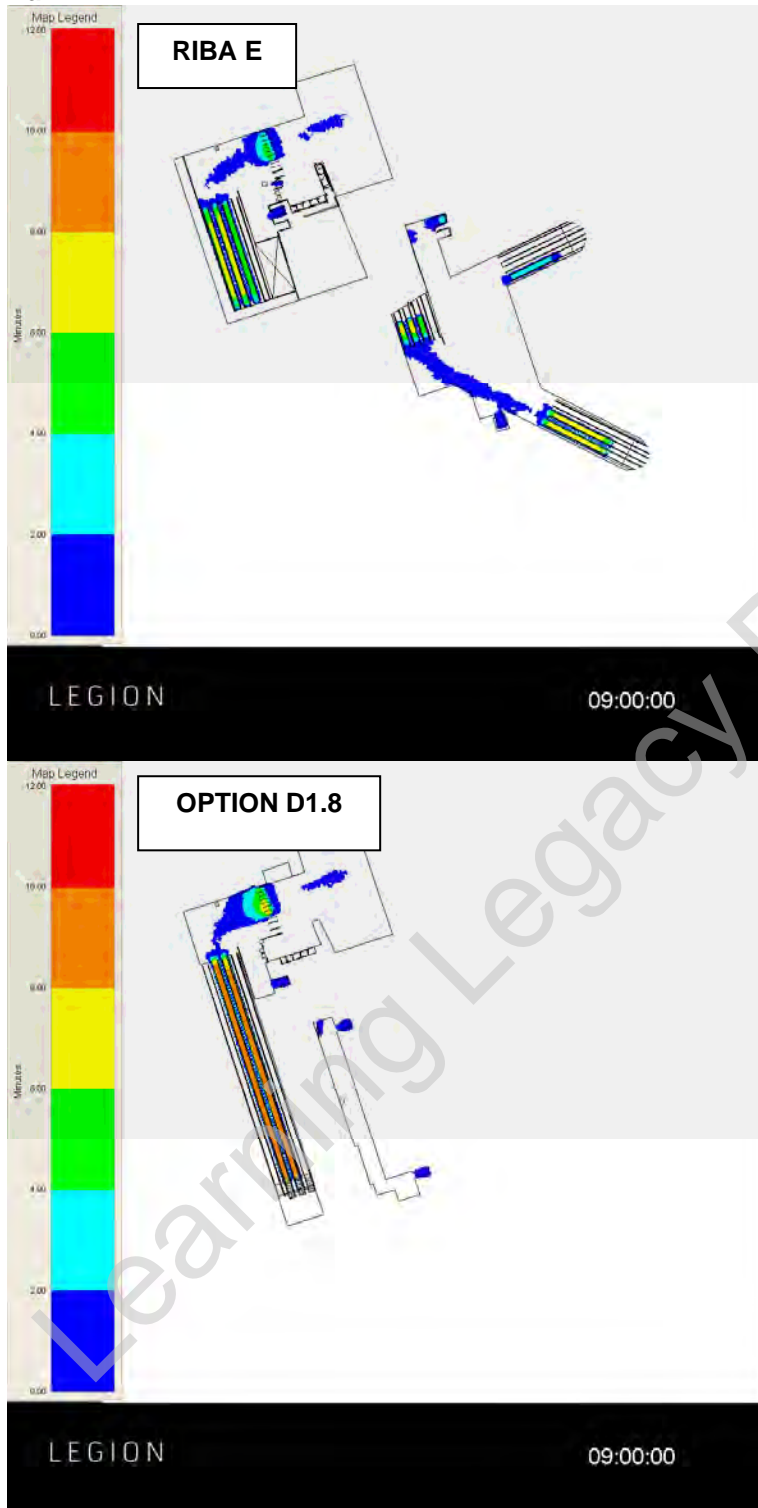

Figure 48: 2026 AM Peak +28% (08:45 - 09:00 hours) CHD 1.08 passengers/m² – Central Line

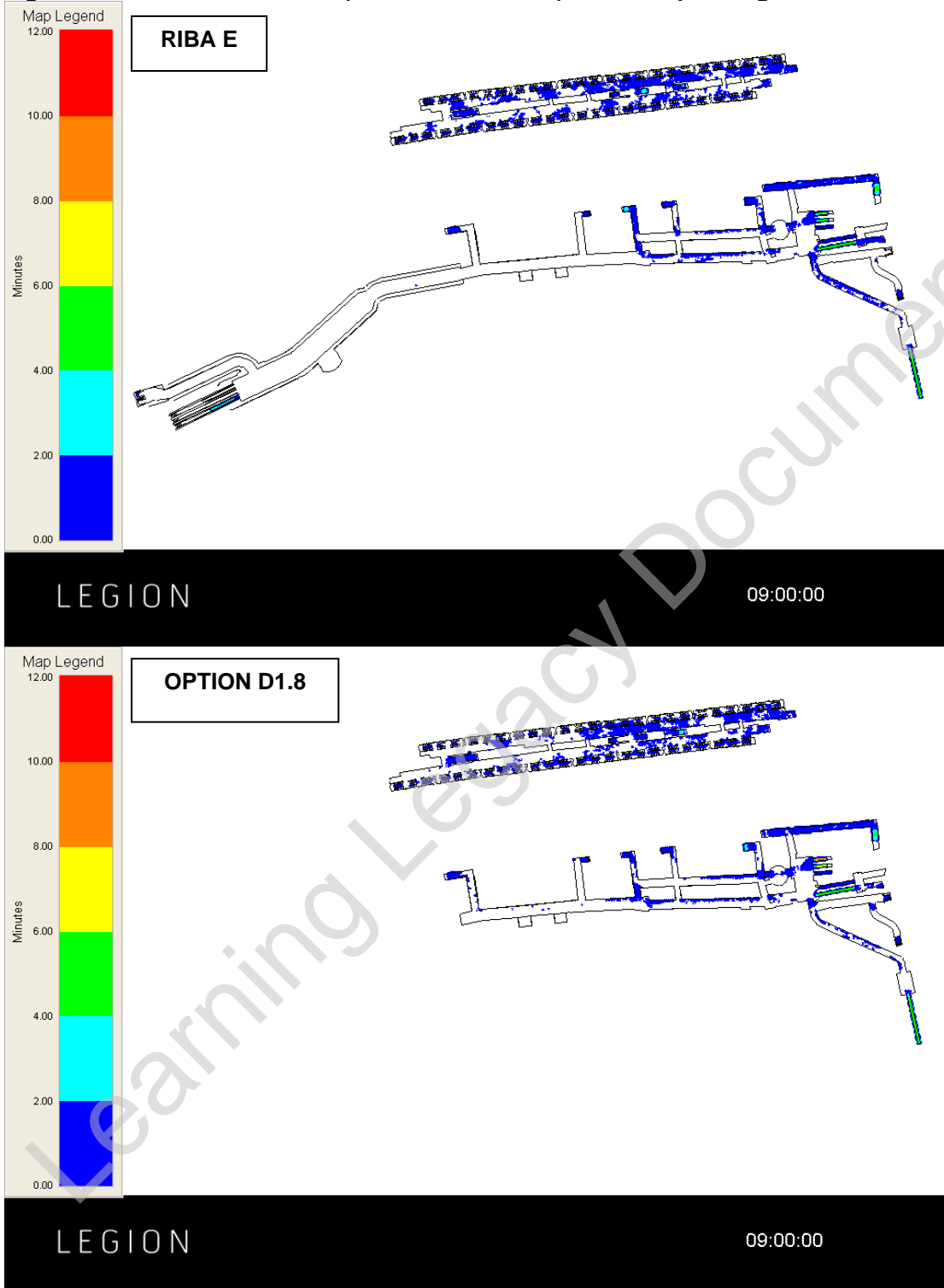
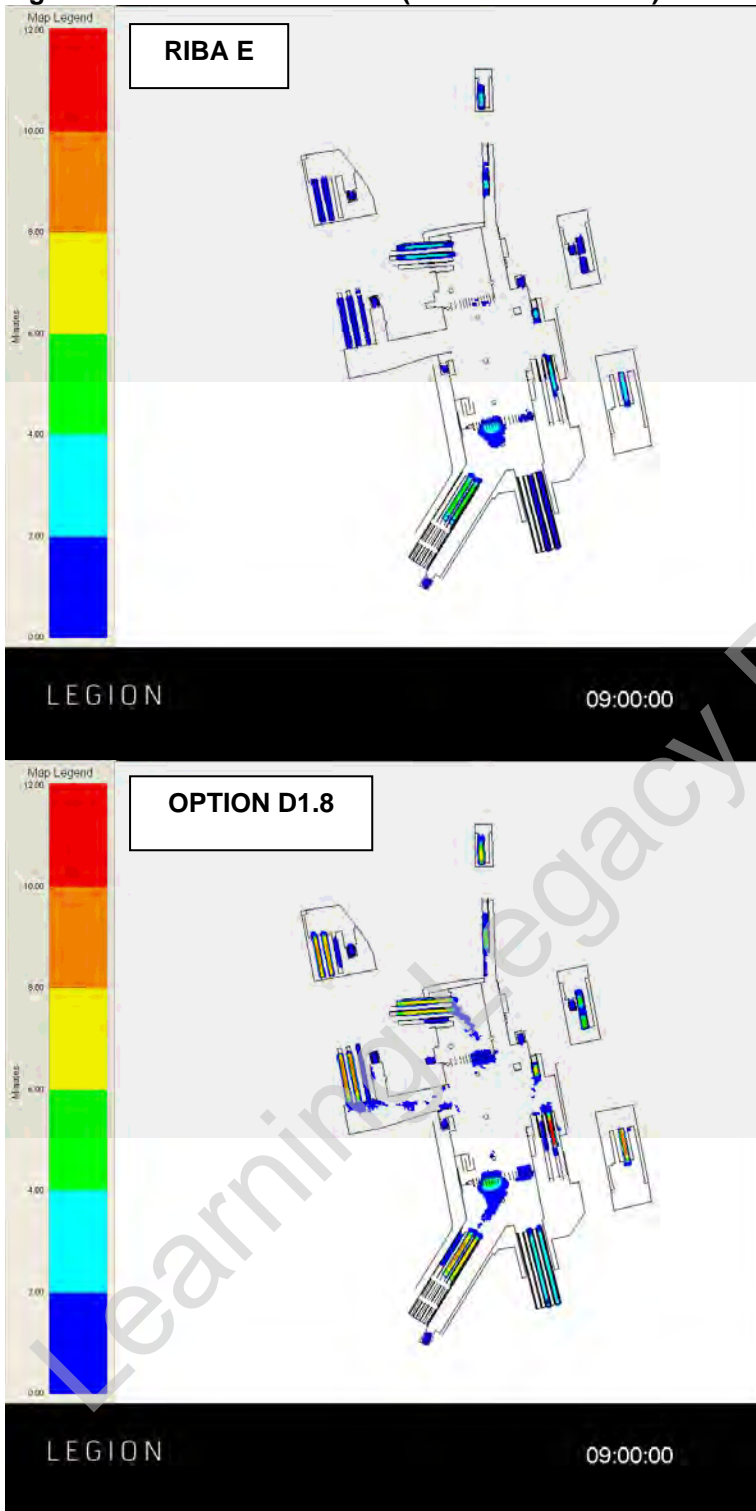

Figure 49: 2026 AM Peak +28% (08:45 - 09:00 hours) CHD 1.08 passengers/m² – Eastern Ticket Hall



13.2 2026 PM Peak +28%

Figure 50: 2026 PM Peak +28% (17:45 - 18:00 hours) CHD 1.08 passengers/m² – Northern Line



Figure 51: 2026 PM Peak +28% (17:45 - 18:00 hours) CHD 1.08 passengers/m² - Crossrail

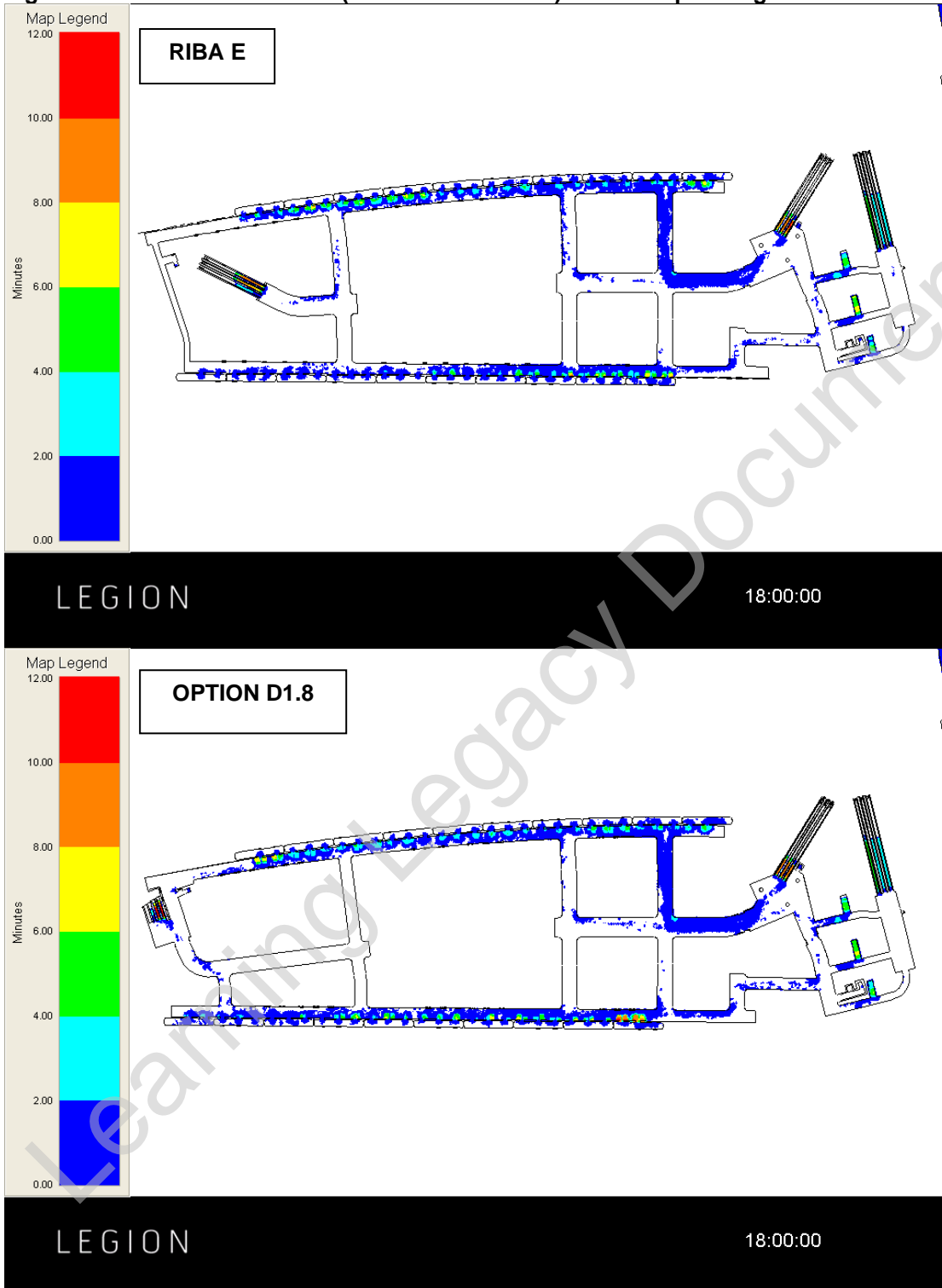

Figure 52: 2026 PM Peak +28% (17:45 - 18:00 hours) CHD 1.08 passengers/m² – Western Ticket Hall

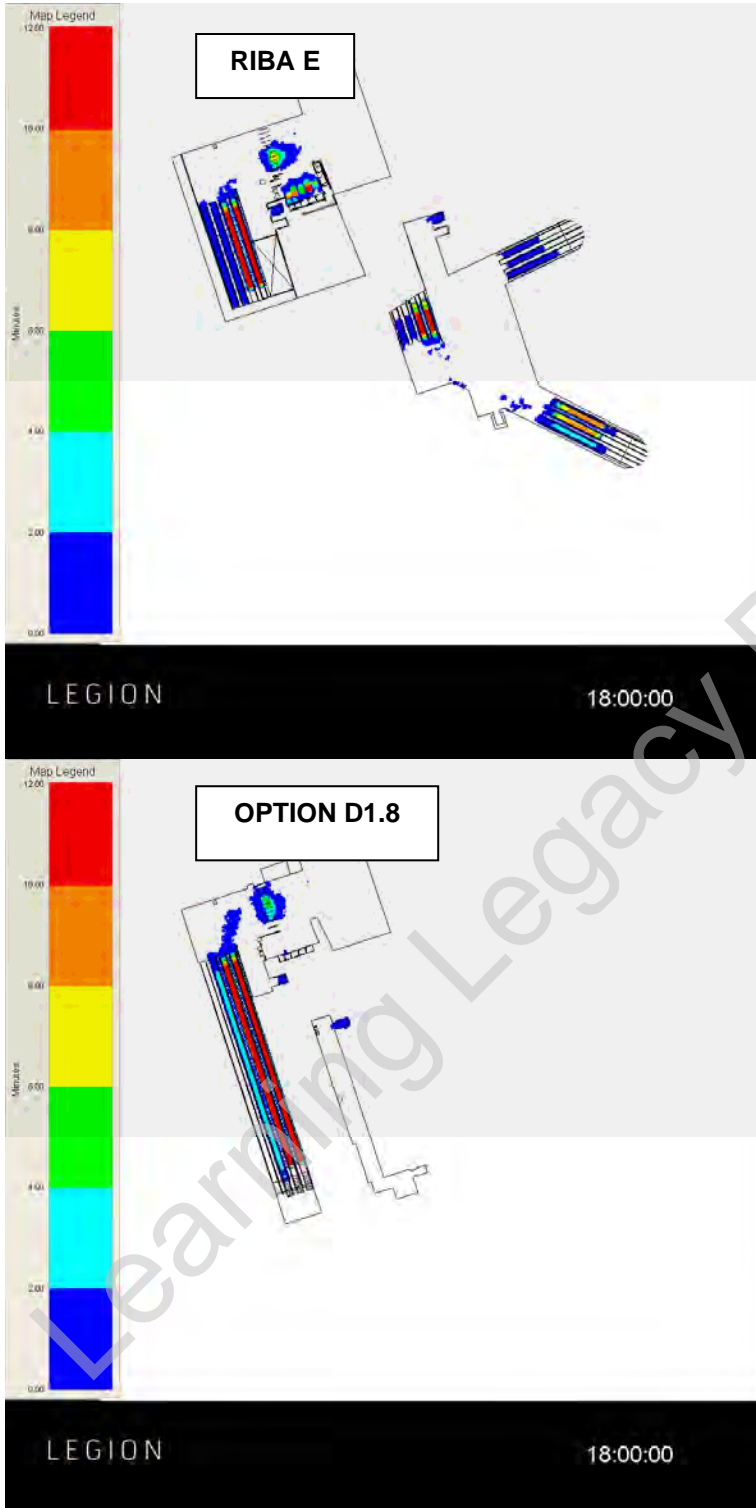

Figure 53: 2026 PM Peak +28% (17:45 - 18:00 hours) CHD 1.08 passengers/m² – Central Line

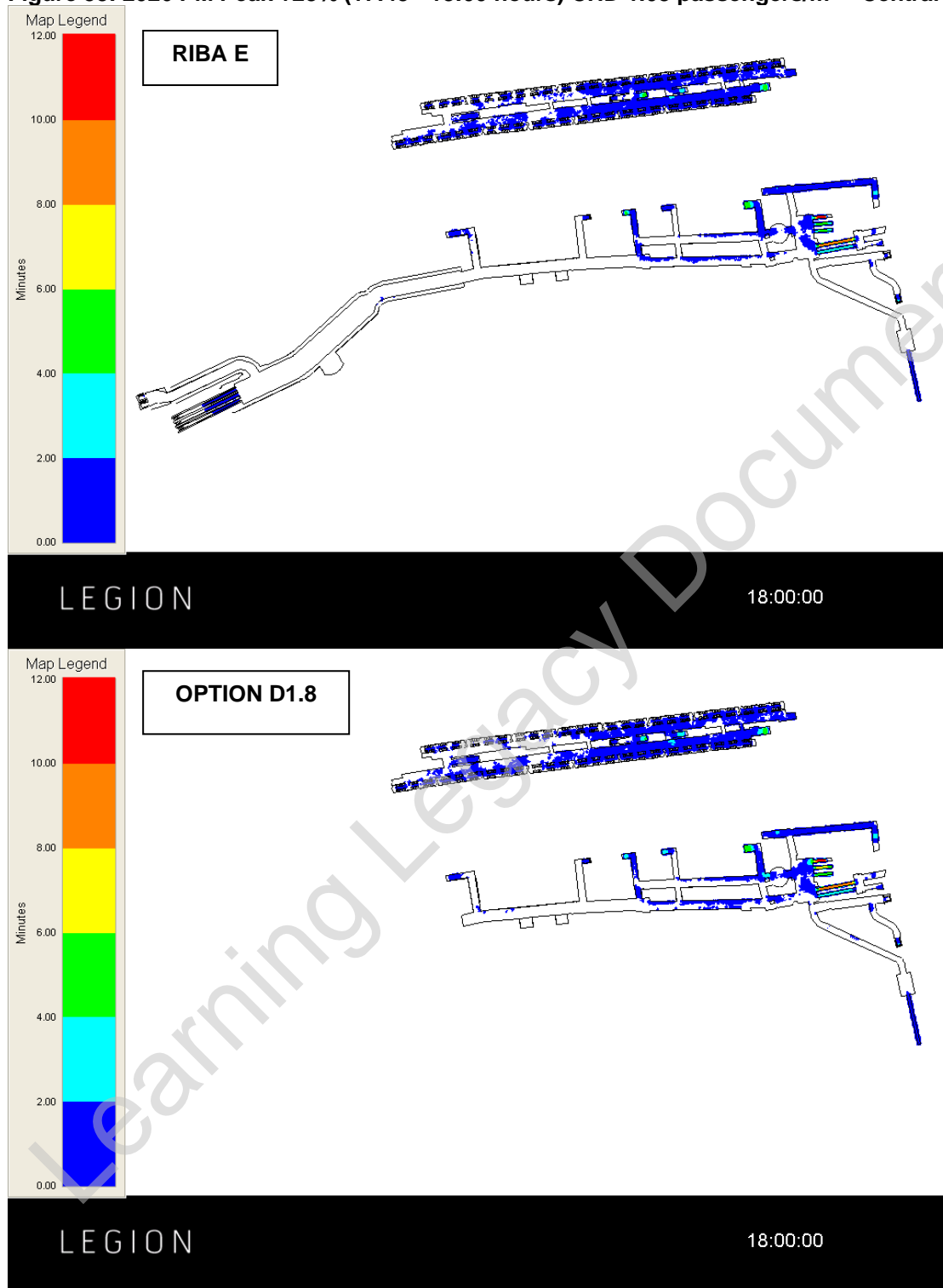
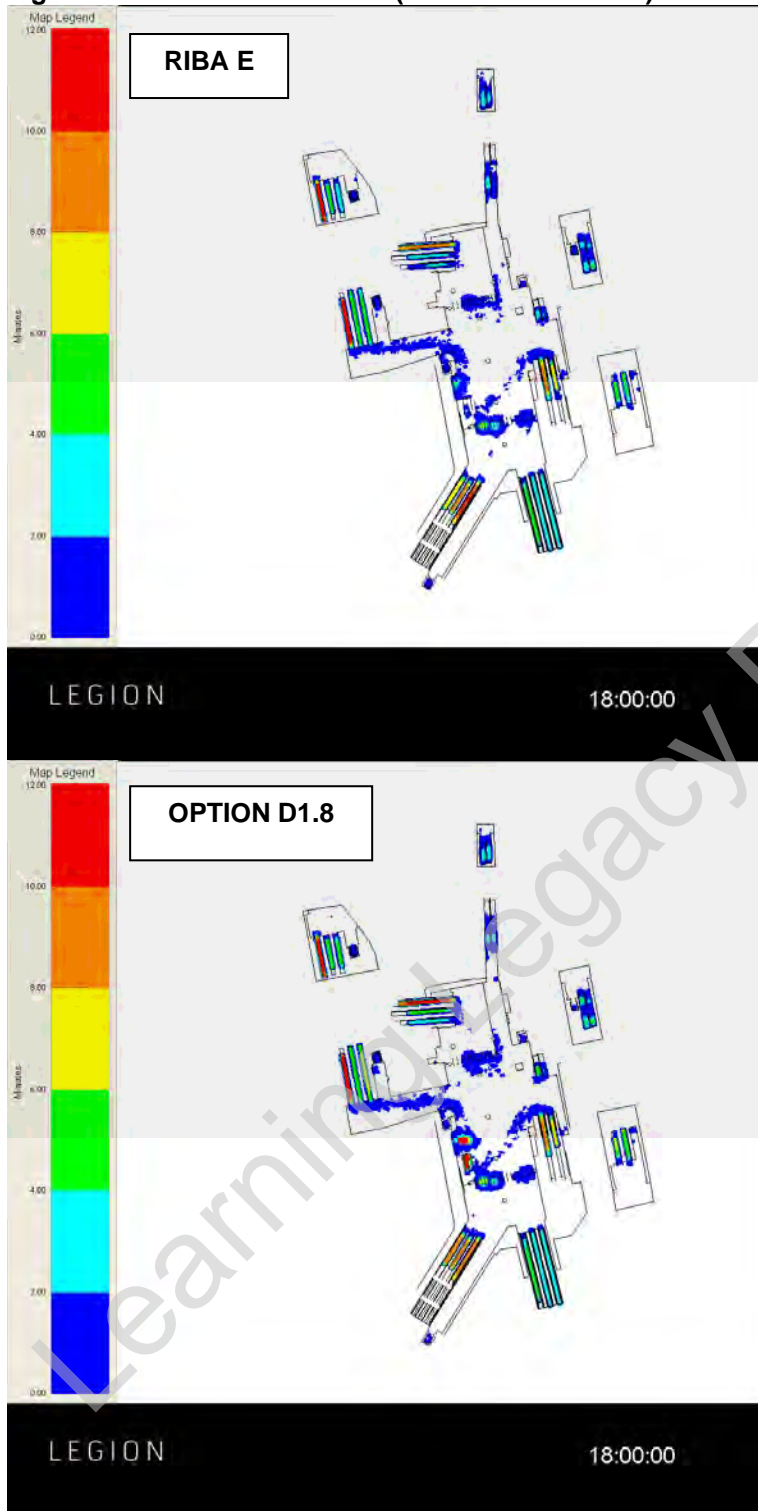

Figure 54: 2026 PM Peak +28%(17:45 - 18:00 hours) CHD 1.08 passengers/m² – Eastern Ticket Hall



14 Appendix E: Peak 15 minutes Cumulative High Density (CHD) Maps – 1.54 passengers/m²

14.1 2026 AM Peak +28%

Figure 55: 2026 AM Peak +28% (08:45 - 09:00 hours) CHD 1.54 passengers/m² – Northern Line

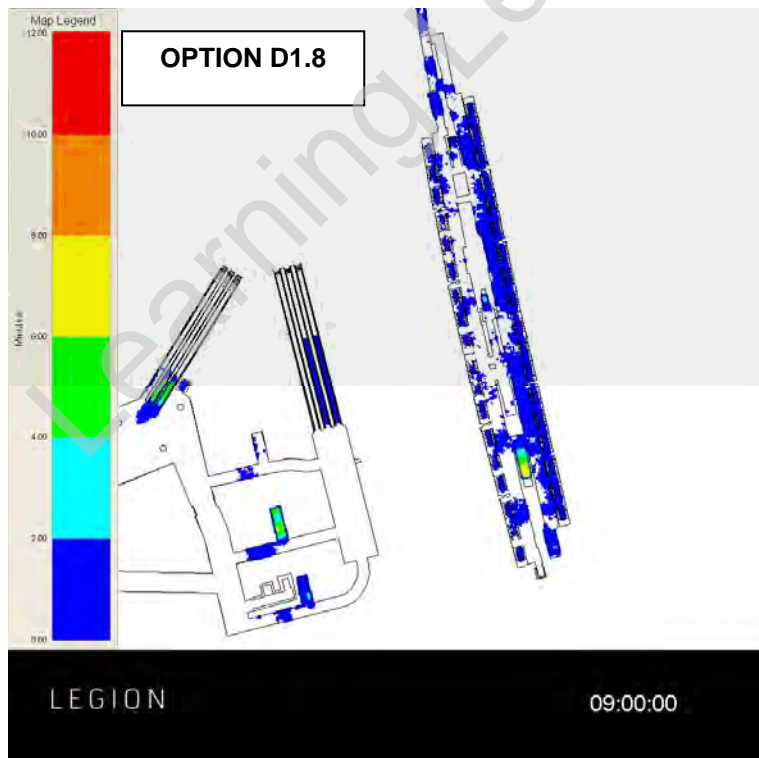
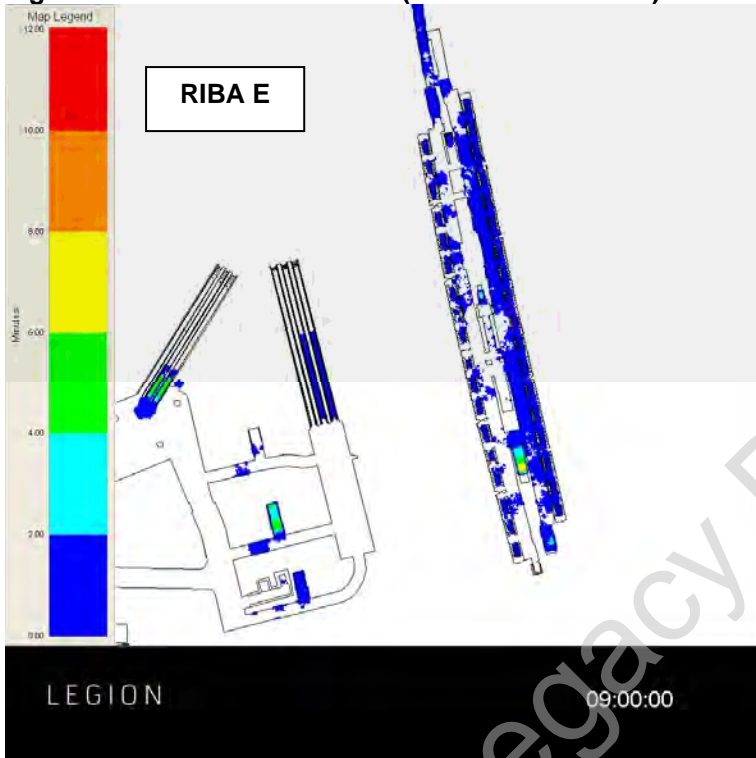

Figure 56: 2026 AM Peak +28% (08:45 - 09:00 hours) CHD 1.54 passengers/m² – Crossrail

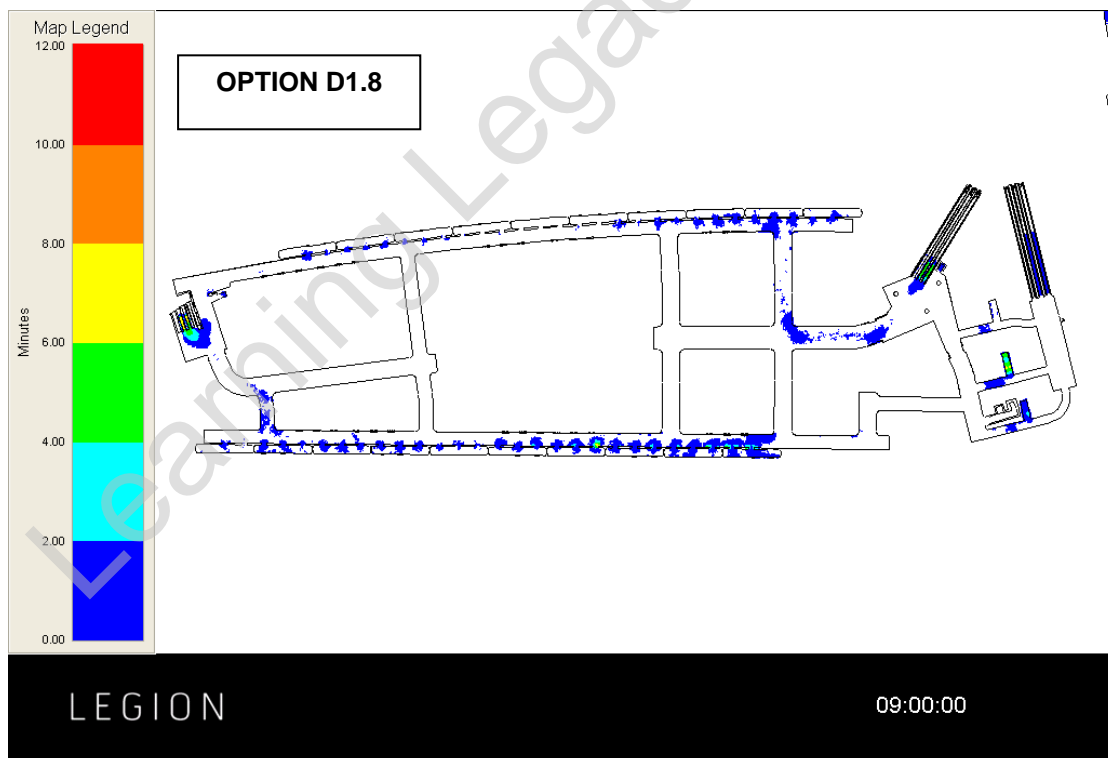
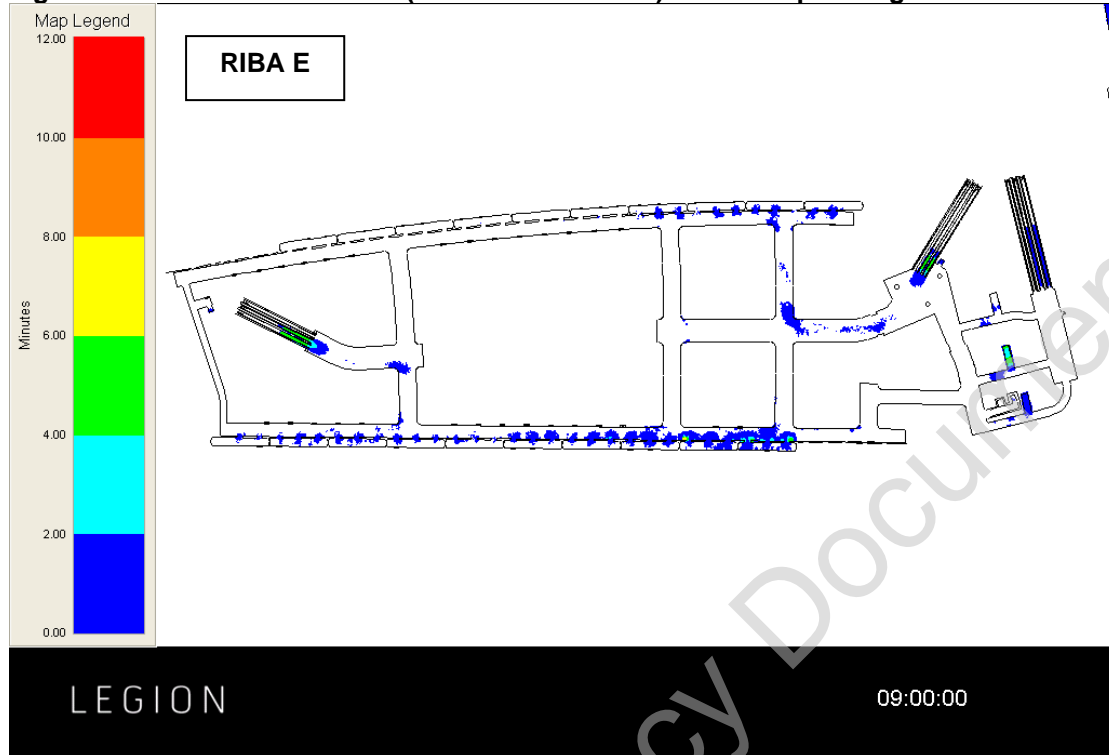

Figure 57: 2026 AM Peak +28% (08:45 - 09:00 hours) CHD 1.54 passengers/m² – Western Ticket Hall

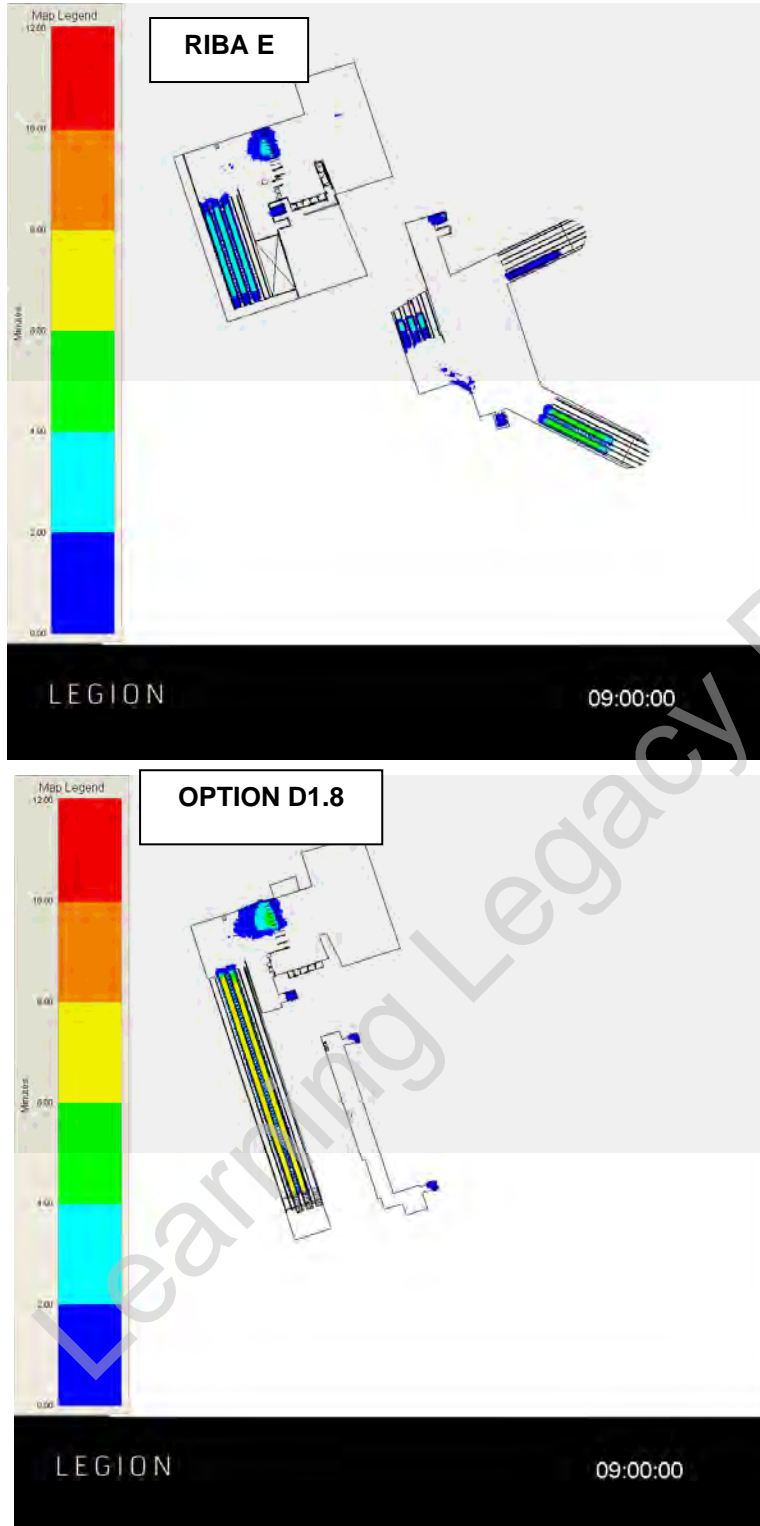

Figure 58: 2026 AM Peak +28% (08:45 - 09:00 hours) CHD 1.54 passengers/m² – Central Line

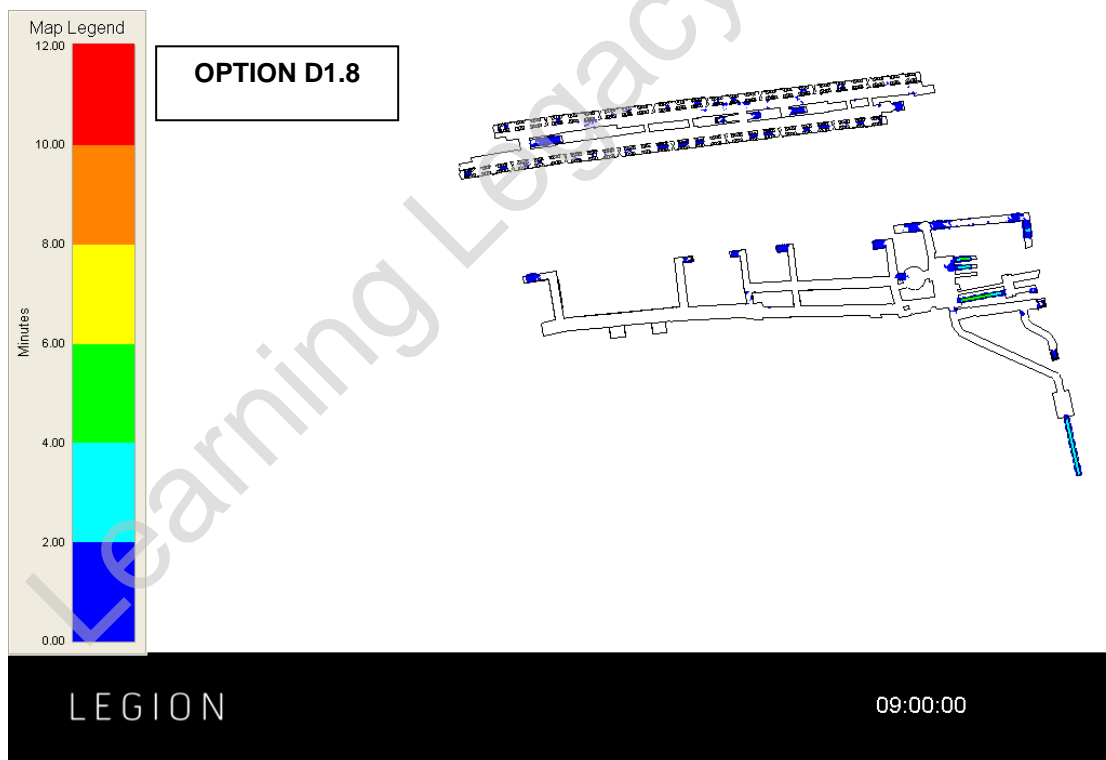
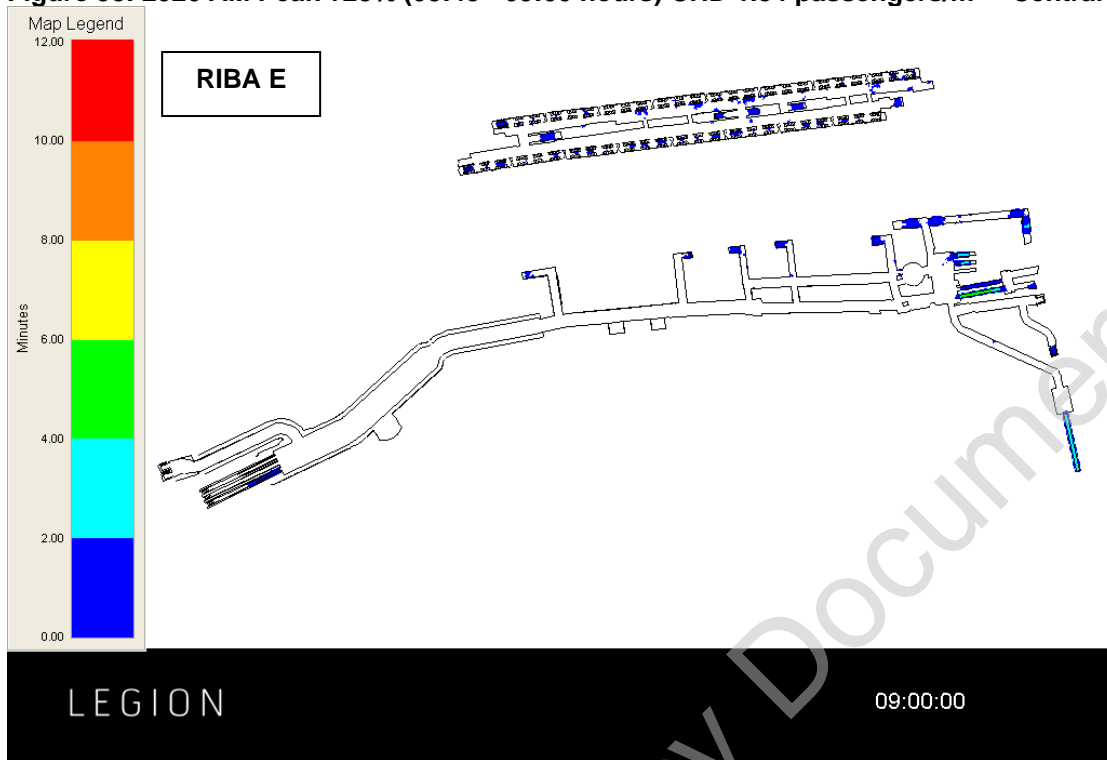
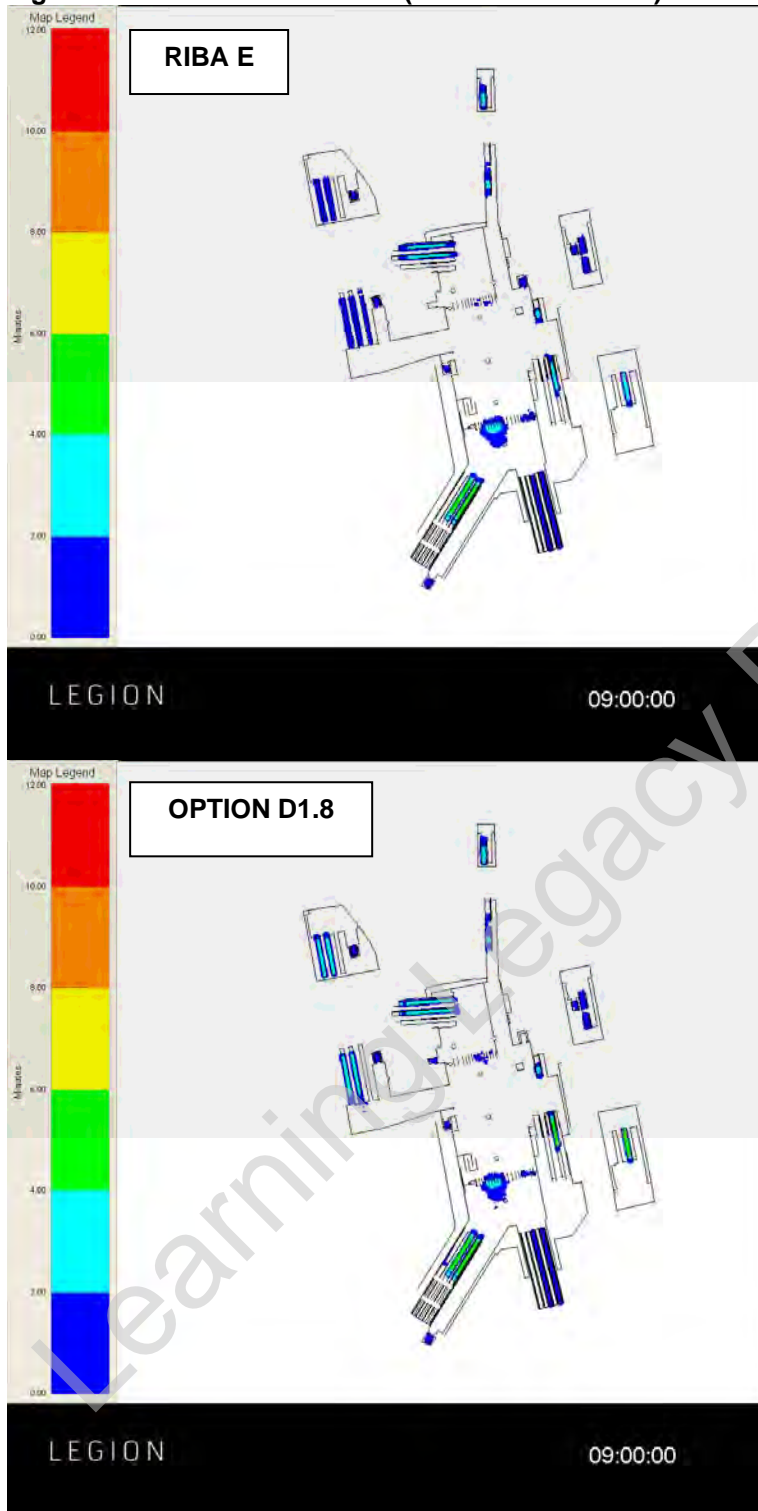

Figure 59: 2026 AM Peak +28% (08:45 - 09:00 hours) CHD 1.54 passengers/m² – Eastern Ticket Hall



14.2 2026 PM Peak +28%

Figure 60: 2026 PM Peak +28% (17:45 - 18:00 hours) CHD 1.54 passengers/m² – Northern Line

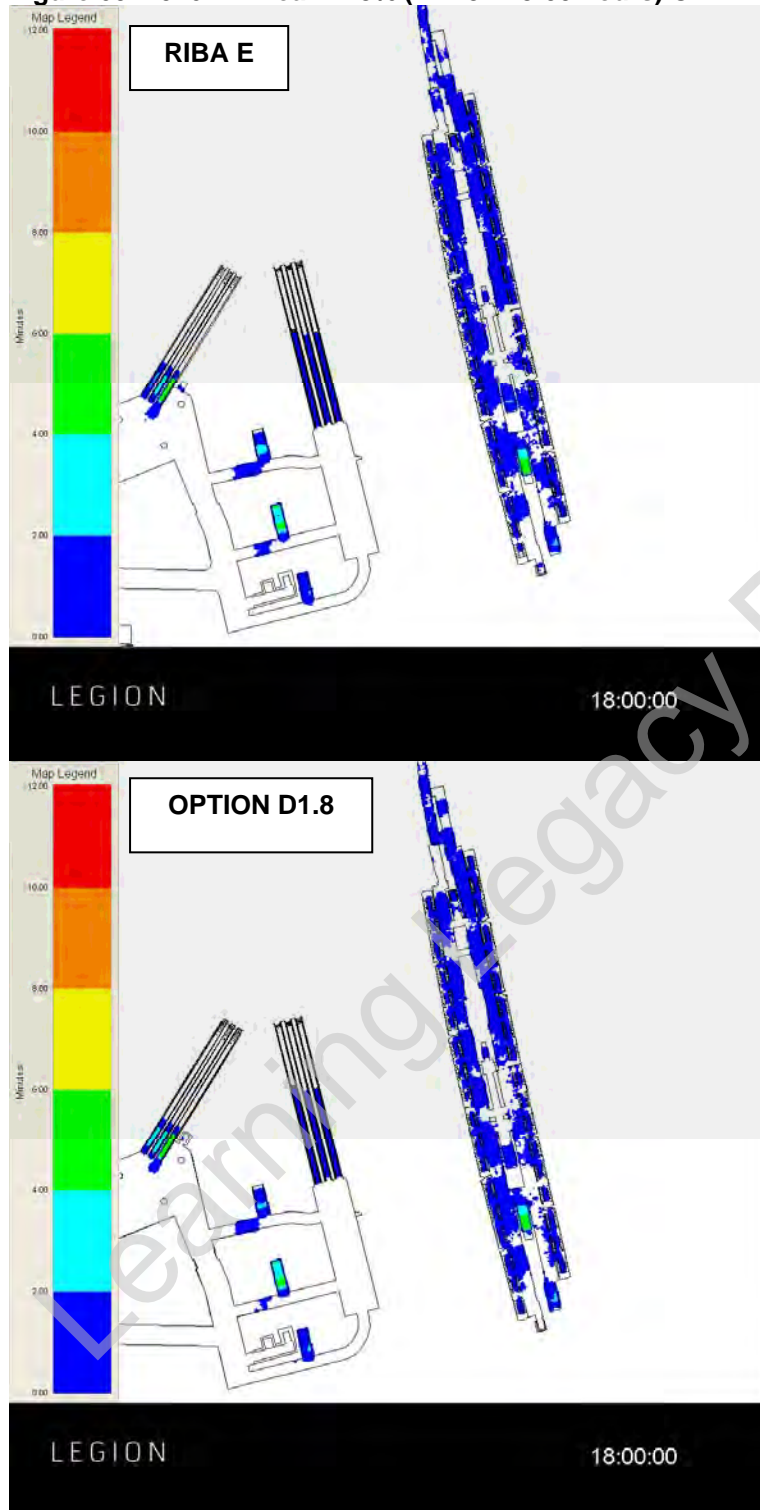

Figure 61: 2026 PM Peak +28% (17:45 - 18:00 hours) CHD 1.54 passengers/m² - Crossrail

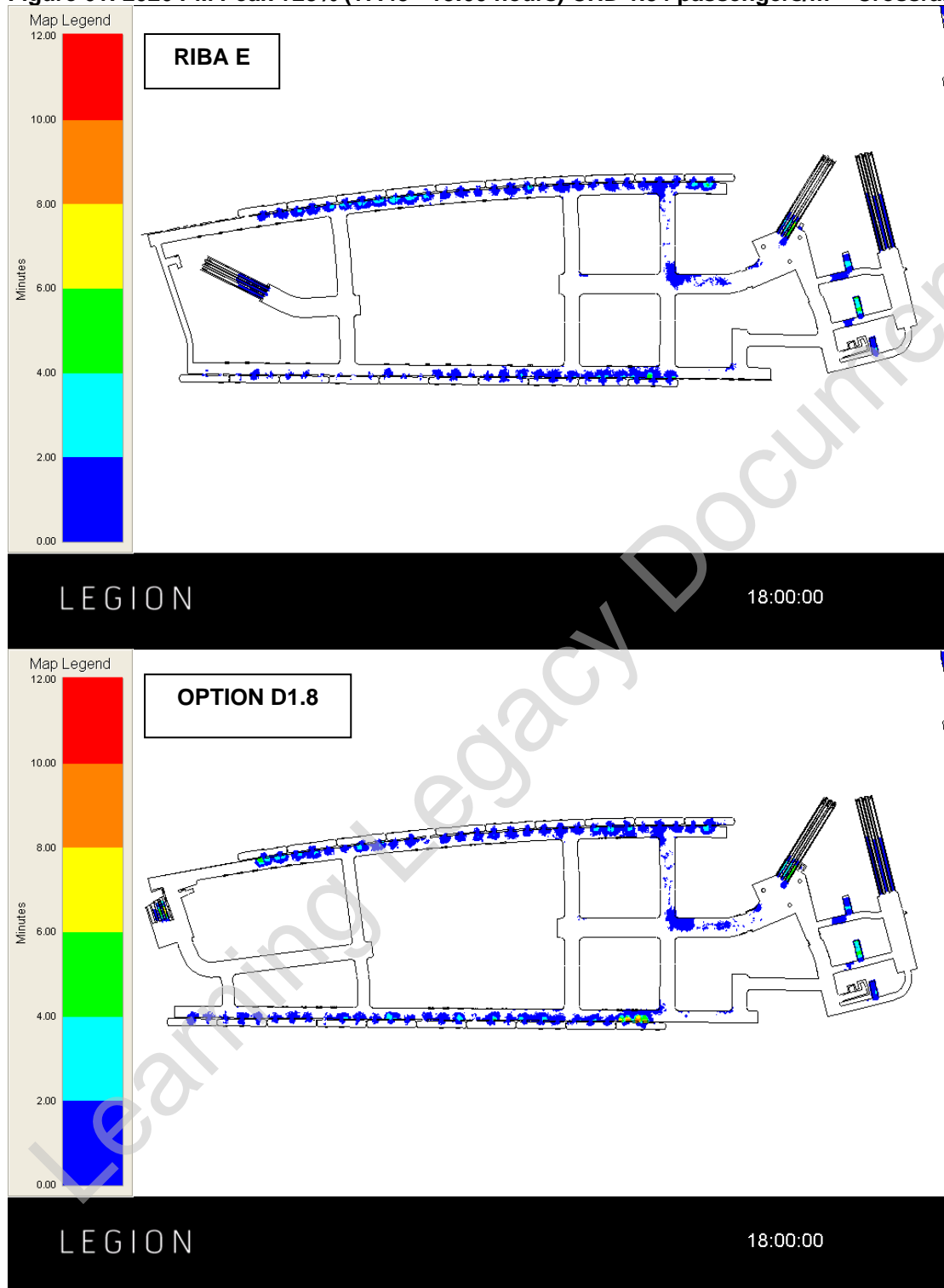

Figure 62: 2026 PM Peak +28% (17:45 - 18:00 hours) CHD 1.54 passengers/m² – Western Ticket Hall

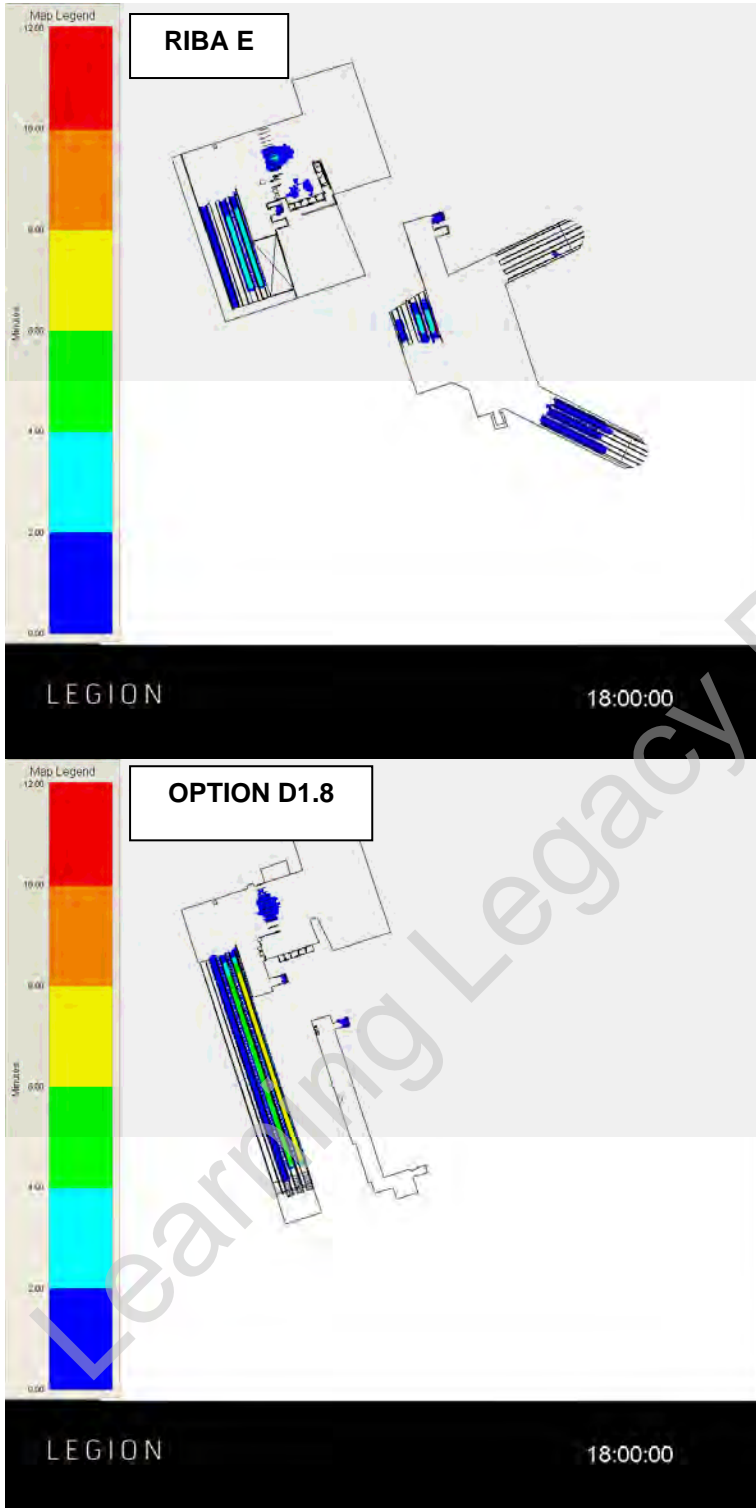

Figure 63: 2026 PM Peak +28% (17:45 - 18:00 hours) CHD 1.54 passengers/m² – Central Line

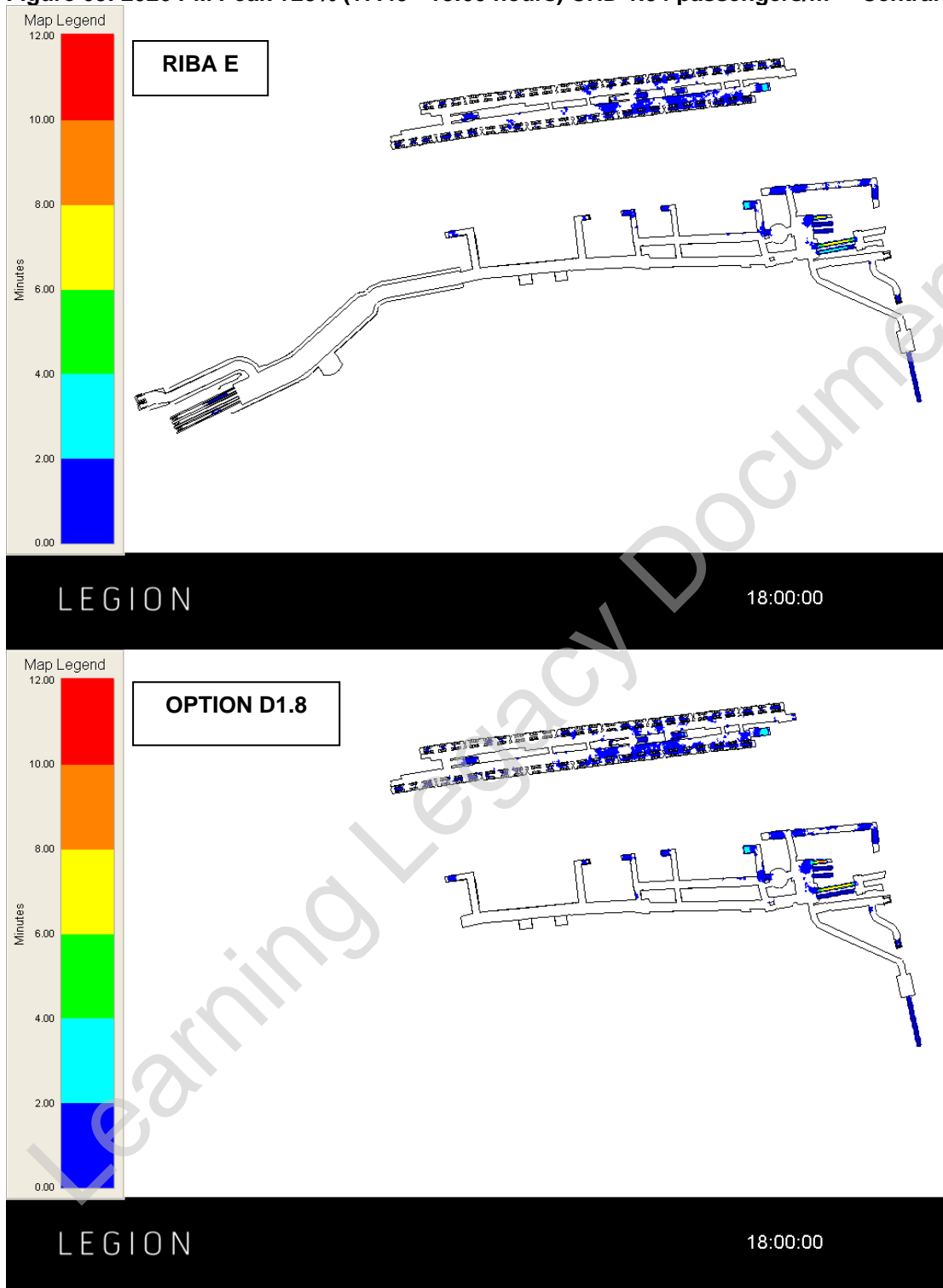
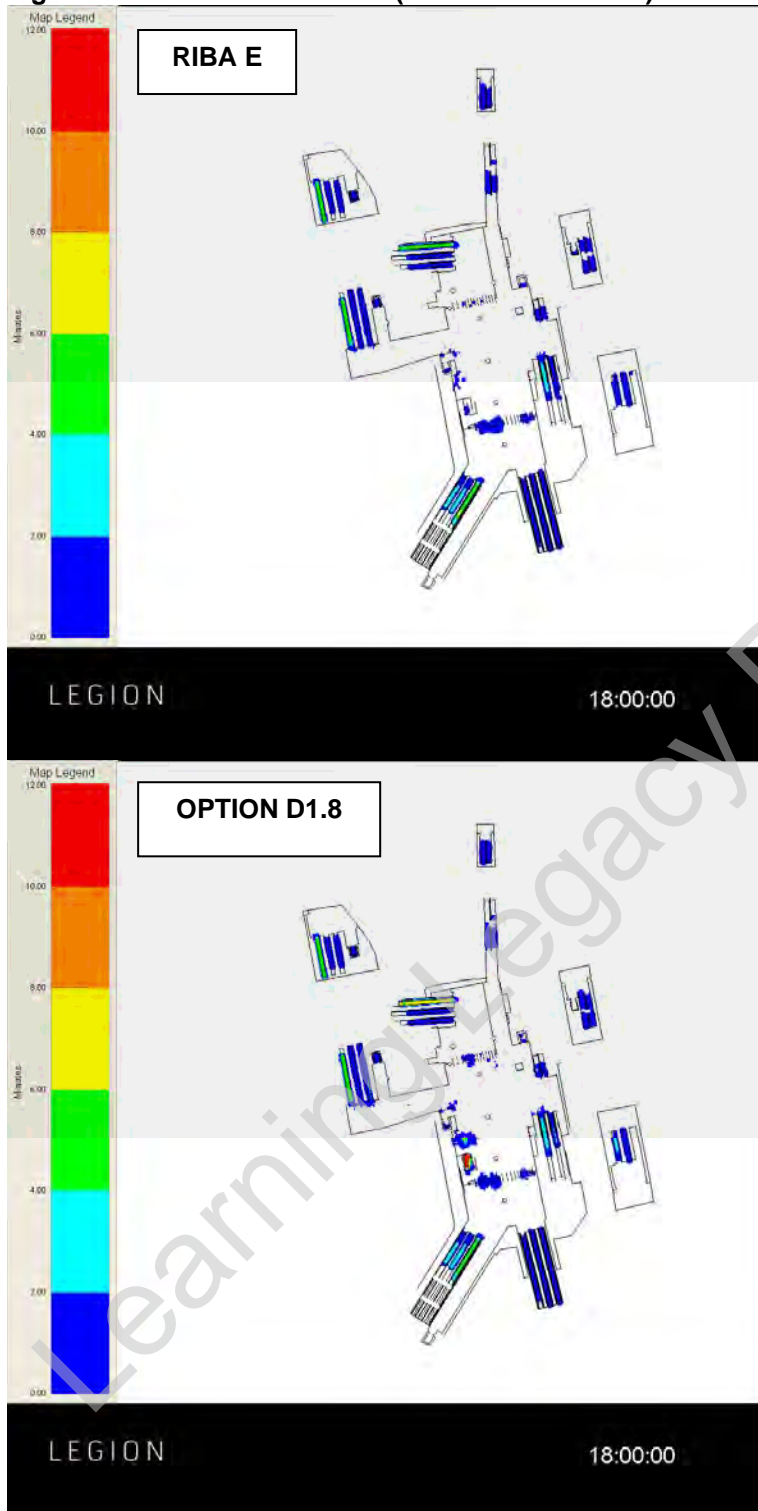

Figure 64: 2026 PM Peak +28%(17:45 - 18:00 hours) CHD 1.54 passengers/m² – Eastern Ticket Hall



15 Appendix F: ‘With Signage’ Routing Scenario – Western Entrance

15.1 Introduction

A brief description of the ‘With Signage’ option for the Western Concourse of Crossrail and a summary of the results and conclusions from this study are presented in this appendix.

A sensitivity test was undertaken to assess the impact of routing 85% passengers to follow the signage and access the Crossrail EB platform using the central concourse and the adit and the remaining 15% to use the shortest route via the western ticket hall box as shown in **Figure 65**.

Passenger flows from/to the Western entrance are shown in **Table 6**.

The operational performance of the Crossrail concourse at the western end resulting from the above routing assumption was assessed using the passenger density maps from the Legion models.

Figure 65: Western Concourse - With Signage Option

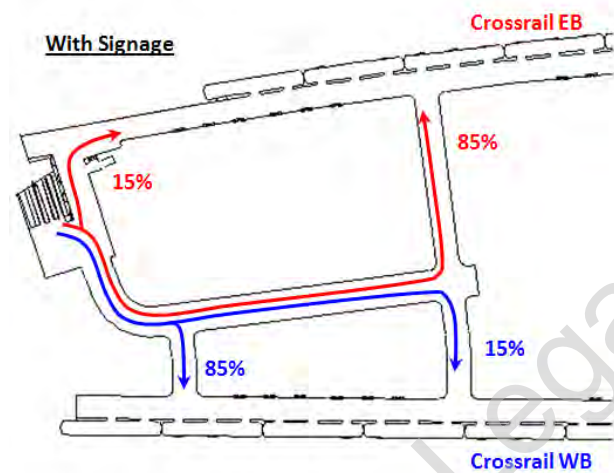

Table 6: 2026 Passenger flows - Western Ticket Hall

	From	To	AM Peak	PM Peak
Station Entry Flows	Western Ticket Hall	Crossrail EB	200	8,550
		Crossrail WB	0	3,500
Station Exit Flows	Crossrail EB	Western Ticket Hall	3,500	150
	Crossrail WB		7,700	1,600

15.2 Results

Figures 66 to 69 show a comparison of the modelling outputs (passenger density maps) for the two routing options tested at the western concourse of Crossrail for the AM and PM peak periods.

Figure 66: CMD walkway – 2026 AM Peak +28% (08:45 – 09:00 hours)

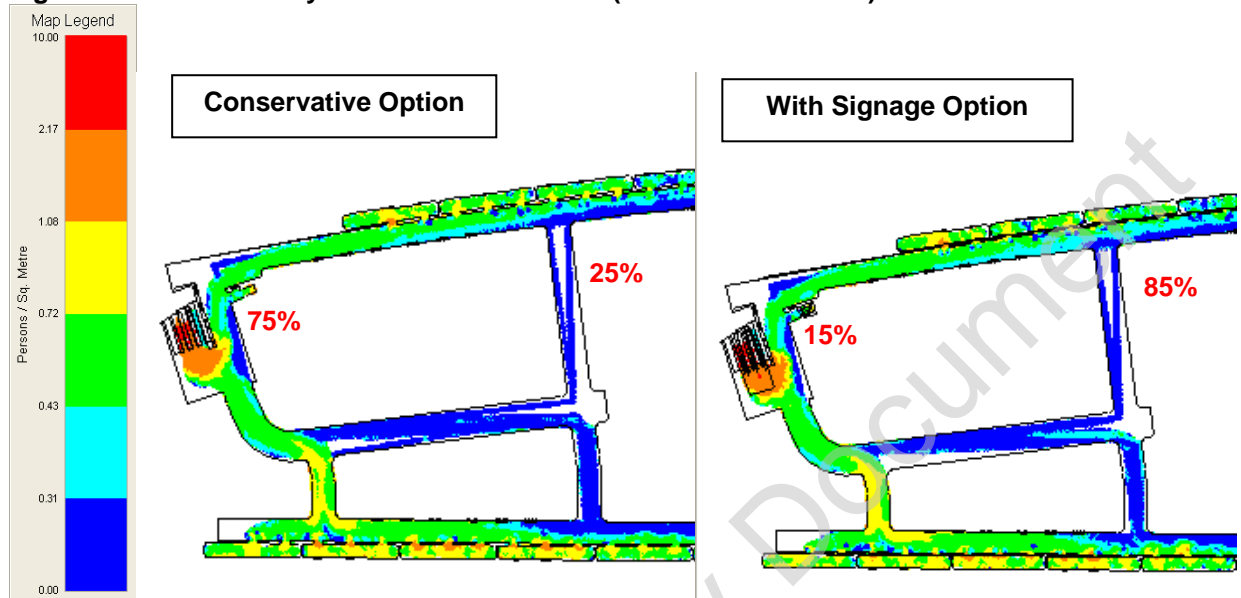

Figure 67: CHD - greater than Walkway LOS C - 0.72 persons/m² (08:45 - 09:00 hours)

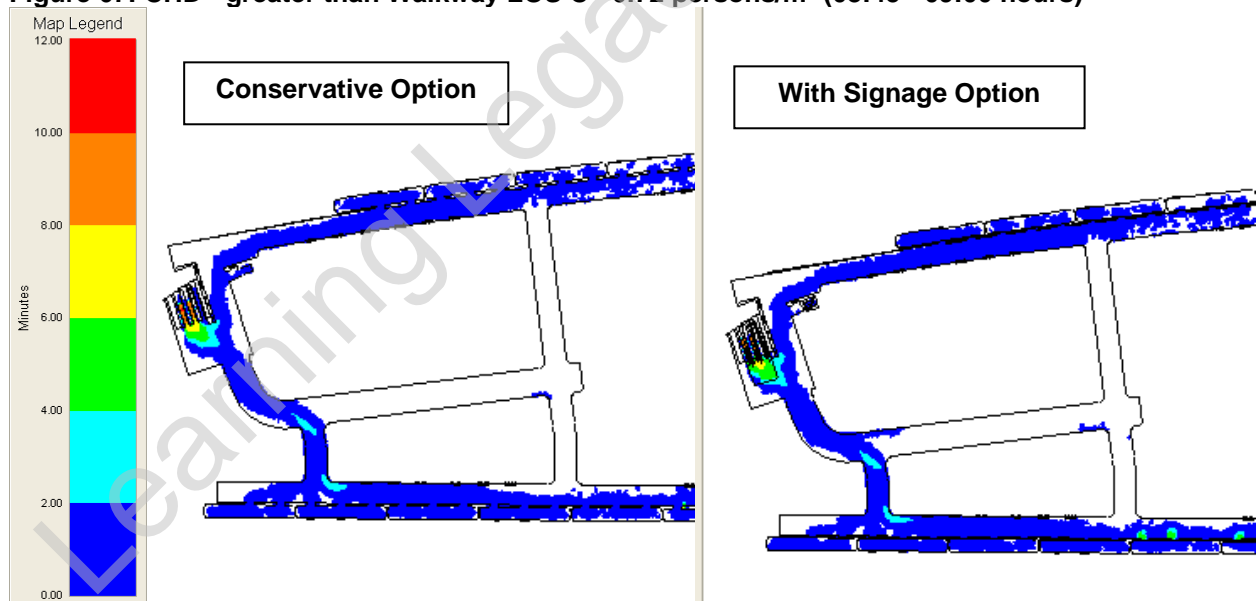

Figure 68: CMD walkway – 2026 PM Peak +28% (17:45 – 18:00 hours)

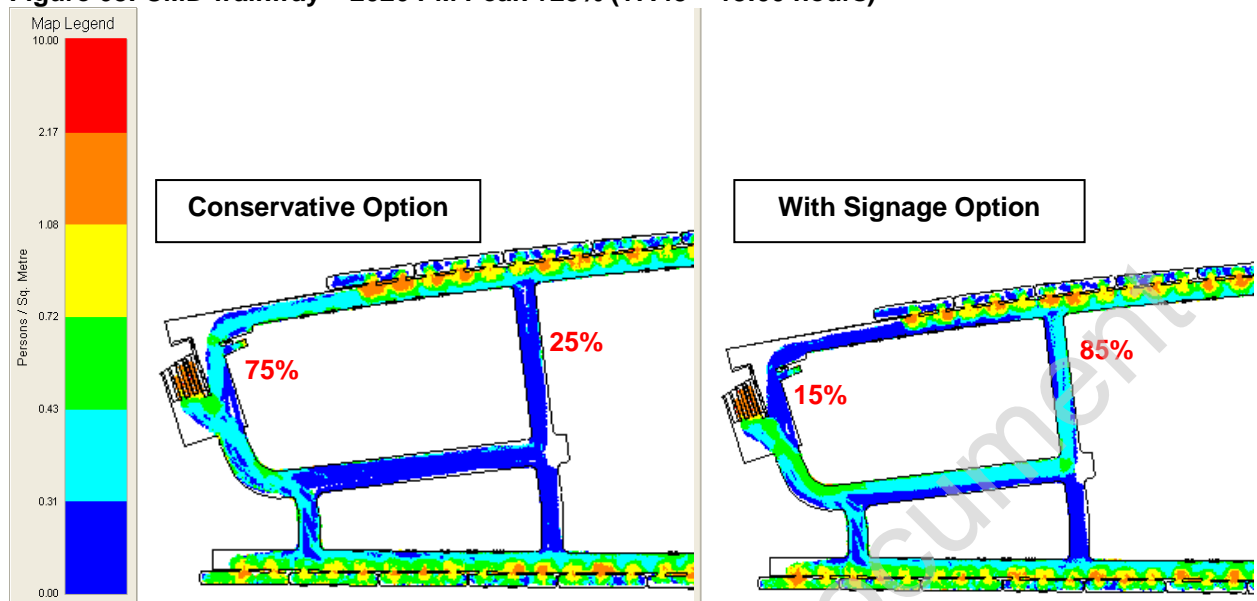
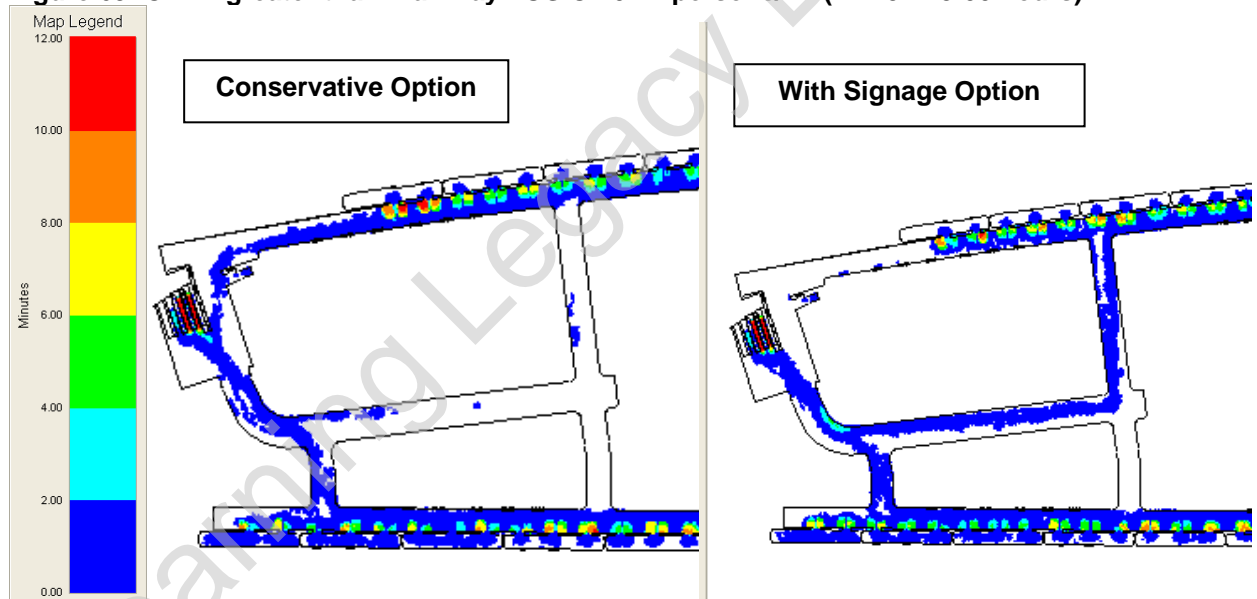

Figure 69: CHD - greater than Walkway LOS C - 0.72 persons/m² (17:45 - 18:00 hours)



The results are summarised as follows:

- The passenger density maps for the AM peak period show that the results are identical in both the routing options tested. This is because of a relatively low passenger flow (200 passengers in peak 3 hours) from the Western TH to Crossrail EB platform in the AM peak.
- The PM peak results show a small increase in passenger density levels within the western central concourse resulting from the 'with signage' option; and consequently an improvement in the passenger density levels within the Western TH box to Crossrail EB platform route.
- In short, it was observed that the western concourse has sufficient capacity to support the passenger management / signage scenario. The overall passenger density levels in both the options tested were within the LU/CRL acceptance limits.

16 Appendix F: Static Analysis – TCR West

16.1 Static Analysis

The static analysis has been undertaken in accordance with the London Underground – Station Planning Standard (version 1-371-A3, 2009).

16.2 Analysis area

The static analysis covers only the Dean Street (western) part of the station. This is because there are no proposed changes to the eastern part of the station. The station has already been tested using both static calculations and dynamic pedestrian modelling using Legion.

The SD3 station design has been modelled in Legion with Line 2 demand. Results of this modelling are shown in “Tottenham Court Road Crossrail Station - Pedestrian Planning SD3 Legion Modelling Report”.

Document Number: CR-SD-TCR-X-RT-00007

16.3 Line 2 Demand

Line 2 demand is based on a hybrid matrix. For the existing flows and Crossrail the 2026 +28% demand as issued with CPFRv5 is used. The CPFR 5.0 matrices were adjusted by transferring the Western Ticket Hall to/from Central Line flows to the Eastern Ticket Hall as suggested by LU/CRL. In addition to the above changes, 350 passengers from Crossrail EB to Western TH in the morning peak matrix of CPFR 5.0 was increased to 3,500. The same proportion was applied to the Western TH to Crossrail WB flows in the evening peak.

The adjusted matrices issued by Crossrail for the purposes of this study are shown in **Tables 1** and **2**.

For the Line 2 flows a matrix created in 2008 using the Hybrid Bill demand is used as shown in **Tables 3** and **4**.

The Line 2 passengers demand was created by CRL in September 2008. This is based on the Hybrid Bill models with 2016 forecast year (not the more recent 2026 models). The demand uses London Plan demand, the proposed 2016 route network and the safeguarded Line 2 route from Epping to Wimbledon. The 2016 matrix is factored up by 35% to represent passenger growth likely when Line 2 is operating.

These matrices have the same theoretical forecast year of 2076 and have been combined to create a hybrid matrix as shown in **Table 5** and **6**.

Table 7: Adjusted CPFR 5.0 Matrices – 2026 AM Peak

2026 With Crossrail - AM Peak Period Demand at Tottenham Court Road									
TCR XR153RuAM	T C R EASTERN SE	T C R DEAN ST SE	T C R NORTHERN (NB)	T C R NORTHERN (SB)	T C R CENTRAL (EB)	T C R CENTRAL (WB)	T C R CROSSRAIL (EB)	T C R CROSSRAIL (WB)	TOTAL
T C R EASTERN SE	-	-	250	300	450	300	500	350	2150
T C R DEAN ST SE	-	-	-	-	-	-	200	0	200
T C R NORTHERN (NB)	3400	-	-	-	1050	400	650	450	5950
T C R NORTHERN (SB)	1900	-	-	-	2550	1950	2900	1800	11100
T C R CENTRAL (EB)	2400	-	750	250	-	-	-	-	3400
T C R CENTRAL (WB)	4000	-	850	0	-	-	-	-	4850
T C R CROSSRAIL (EB)	2600	3500	1300	800	-	-	-	-	8200
T C R CROSSRAIL (WB)	5800	7700	750	1800	-	-	-	-	16050
TOTAL	20100	11200	3900	3150	4050	2650	4250	2600	51900

Table 8: Adjusted CPFR 5.0 Matrices - 2026 PM Peak

2026 With Crossrail - PM Peak Period Demand at Tottenham Court Road									
TCR XR153RuPM	T C R EASTERN SE	T C R DEAN ST SE	T C R NORTHERN (NB)	T C R NORTHERN (SB)	T C R CENTRAL (EB)	T C R CENTRAL (WB)	T C R CROSSRAIL (EB)	T C R CROSSRAIL (WB)	TOTAL
T C R EASTERN SE	-	-	2700	1500	3050	3200	6450	2900	19800
T C R DEAN ST SE	-	-	-	-	-	-	8550	3500	12050
T C R NORTHERN (NB)	2800	-	-	-	0	550	2400	1050	6800
T C R NORTHERN (SB)	3650	-	-	-	1600	1200	1000	1750	9200
T C R CENTRAL (EB)	2900	-	2250	1250	-	-	-	-	6400
T C R CENTRAL (WB)	2850	-	2100	1950	-	-	-	-	6900
T C R CROSSRAIL (EB)	2450	150	2400	600	-	-	-	-	5600
T C R CROSSRAIL (WB)	3650	1600	3850	850	-	-	-	-	9950
TOTAL	18300	1750	13300	6150	4650	4950	18400	9200	76700

Table 9: Line 2 Demand Forecast (Hybrid Bill – 2008) – AM Peak

Tottenham Court Road - Line 2 Demand Forecast												
	TOTTENHAM COURT ROAD EASTERN SE	TOTTENHAM COURT ROAD DEAN ST SE	TOTTENHAM C R, SHAFTERSBURY AVE	TOTTENHAM COURT RD NOR (CX-NB)	TOTTENHAM COURT RD NOR (CX-SB)	TOTTENHAM COURT ROAD CENT (EB)	TOTTENHAM COURT ROAD CENT (WB)	TOTTENHAM CT RD CROSSRAIL (EB)	TOTTENHAM CT RD CROSSRAIL (WB)	TOTTENHAM CT RD LINE 2 (NB)	TOTTENHAM CT RD LINE 2 (SB)	TOTAL
AM Line2 2016 +35%												
TOTTENHAM COURT ROAD EASTERN SE				150	600	550	250	250	200	100	100	2200
TOTTENHAM COURT ROAD DEAN ST SE						200	150	400	150	100	50	1050
TOTTENHAM C R, SHAFTERSBURY AVE										250	150	400
TOTTENHAM COURT RD NOR (CX-NB)	5800					950	200	1100	1200	50	0	9300
TOTTENHAM COURT RD NOR (CX-SB)	3000					1400	2700	1800	1800	50	150	10900
TOTTENHAM COURT ROAD CENT (EB)	2600	900		900	250			50	0	450	250	5400
TOTTENHAM COURT ROAD CENT (WB)	2700	1400		400	0			0	50	50	200	4800
TOTTENHAM CT RD CROSSRAIL (EB)	2600	800		2700	2600	100	0			1500	1400	11700
TOTTENHAM CT RD CROSSRAIL (WB)	4100	7000		4100	3100	0	100			250	4100	22750
TOTTENHAM CT RD LINE 2 (NB)	2700	1800	4900	600	0	4300	800	3000	2300			20400
TOTTENHAM CT RD LINE 2 (SB)	2100	2500	5000	550	0	800	2000	250	3500			16700
TOTAL	25600	14400	9900	9400	6550	8300	6200	6850	9200	2800	6400	105600

Table 10: Line 2 Demand Forecast (Hybrid Bill – 2008) – PM Peak

Tottenham Court Road - Line 2 Demand Forecast												
	TOTTENHAM COURT ROAD EASTERN SE	TOTTENHAM COURT ROAD DEAN ST SE	TOTTENHAM C R, SHAFTERSBURY AVE	TOTTENHAM COURT RD NOR (CX-NB)	TOTTENHAM COURT RD NOR (CX-SB)	TOTTENHAM COURT ROAD CENT (EB)	TOTTENHAM COURT ROAD CENT (WB)	TOTTENHAM CT RD CROSSRAIL (EB)	TOTTENHAM CT RD CROSSRAIL (WB)	TOTTENHAM CT RD LINE 2 (NB)	TOTTENHAM CT RD LINE 2 (SB)	TOTAL
PM Line2 2016 +35%												
TOTTENHAM COURT ROAD EASTERN SE				3000	5800	2700	2600	4100	2600	1700	2100	24600
TOTTENHAM COURT ROAD DEAN ST SE						1400	900	7000	800	1900	1400	13400
TOTTENHAM C R, SHAFTERSBURY AVE										6000	5900	11900
TOTTENHAM COURT RD NOR (CX-NB)	6600					0	300	3400	2800	0	0	13100
TOTTENHAM COURT RD NOR (CX-SB)	1500					450	950	4400	2900	600	650	11450
TOTTENHAM COURT ROAD CENT (EB)	2900	1500		2900	200			50	0	2200	850	10600
TOTTENHAM COURT ROAD CENT (WB)	5900	2200		1500	1000			0	50	900	4700	16250
TOTTENHAM CT RD CROSSRAIL (EB)	2200	1500		1900	1300	50	0			3800	2500	13250
TOTTENHAM CT RD CROSSRAIL (WB)	2900	4400		1900	1200	0	50			300	3200	13950
TOTTENHAM CT RD LINE 2 (NB)	700	350	1100	150	0	200	300	4400	1500			8700
TOTTENHAM CT RD LINE 2 (SB)	1100	1100	2300	50	50	50	500	300	1600			7050
TOTAL	23800	11050	3400	11400	9550	4850	5600	23650	12250	17400	21300	144250

NOTES:
Base = Railplan Hybrid Bill, CRA44
Line 2 flows assume safeguarded alignment (Epping to Wimbledon)
Flows are re-assignment only.
Line 2 will not be operational in 2016 so are factored up by +35%.

Table 11: Hybrid Matrix used for Static Analysis – AM Peak

Tottenham Court Road - Demand Forecast (AM_Line2)											
To \ From	TCR EASTERN SE	TCR DEAN ST SE	TCR NOR (CX-NB)	TCR NOR (CX-SB)	TCR CENT (EB)	TCR CENT (WB)	TCR CROSSRAIL (EB)	TCR CROSSRAIL (WB)	TCR LINE 2 (NB)	TCR LINE 2 (SB)	TOTAL
TCR EASTERN SE	0	0	320	384	576	384	640	448	100	100	2,952
TCR DEAN ST SE	0	0	0	0	0	0	256	0	100	50	406
TCR NOR (CX-NB)	4,352	0	0	0	1,344	512	832	576	50	0	7,666
TCR NOR (CX-SB)	2,432	0	0	0	3,264	2,496	3,712	2,304	50	150	14,408
TCR CENT (EB)	3,072	0	960	320	0	0	0	0	450	250	5,052
TCR CENT (WB)	5,120	0	1,088	0	0	0	0	0	50	200	6,458
TCR CROSSRAIL (EB)	3,328	4,480	1,664	1,024	0	0	0	0	1,500	1,400	13,396
TCR CROSSRAIL (WB)	7,424	9,856	960	2,304	0	0	0	0	250	4,100	24,894
TCR LINE 2 (NB)	2,700	1,800	600	0	4,300	800	3,000	2,300	0	0	15,500
TCR LINE 2 (SB)	2,100	2,500	550	0	800	2,000	250	3,500	0	0	11,700
TOTAL	30,528	18,636	6,142	4,032	10,284	6,192	8,690	9,128	2,550	6,250	102,432

Table 12: Hybrid Matrix used for Static Analysis – PM Peak

Tottenham Court Road - Demand Forecast (PM_Line2)											
To \ From	TCR EASTERN SE	TCR DEAN ST SE	TCR NOR (CX-NB)	TCR NOR (CX-SB)	TCR CENT (EB)	TCR CENT (WB)	TCR CROSSRAIL (EB)	TCR CROSSRAIL (WB)	TCR LINE 2 (NB)	TCR LINE 2 (SB)	TOTAL
TCR EASTERN SE	0	0	3,456	1,920	3,904	4,096	8,256	3,712	1,700	2,100	29,144
TCR DEAN ST SE	0	0	0	0	0	0	10,944	4,480	1,900	1,400	18,724
TCR NOR (CX-NB)	3,584	0	0	0	0	704	3,072	1,344	0	0	8,704
TCR NOR (CX-SB)	4,672	0	0	0	2,048	1,536	1,280	2,240	600	650	13,026
TCR CENT (EB)	3,712	0	2,880	1,600	0	0	0	0	2,200	850	11,242
TCR CENT (WB)	3,648	0	2,688	2,496	0	0	0	0	900	4,700	14,432
TCR CROSSRAIL (EB)	3,136	192	3,072	768	0	0	0	0	3,800	2,500	13,468
TCR CROSSRAIL (WB)	4,672	2,048	4,928	1,088	0	0	0	0	300	3,200	16,236
TCR LINE 2 (NB)	700	350	150	0	200	300	4,400	1,500	0	0	7,600
TCR LINE 2 (SB)	1,100	1,100	50	50	50	500	300	1,600	0	0	4,750
TOTAL	25,224	3,690	17,224	7,922	6,202	7,136	28,252	14,876	11,400	15,400	137,326

16.4 Comparison of Crossrail and Line 2 demand

Figure 1 shows a comparison of the CPFRv5 2026+28% and hybrid matrix Line 2 demand. With the introduction of Line 2 Dean Street entry and exits increase by 30% and interchange becomes the largest movement in the AM peak. Dean Street entry and exits increase by 27% and interchange is still the largest movement in the PM peak.

Figure 70: Comparison of 2076 Crossrail and Line 2 demand forecasts.

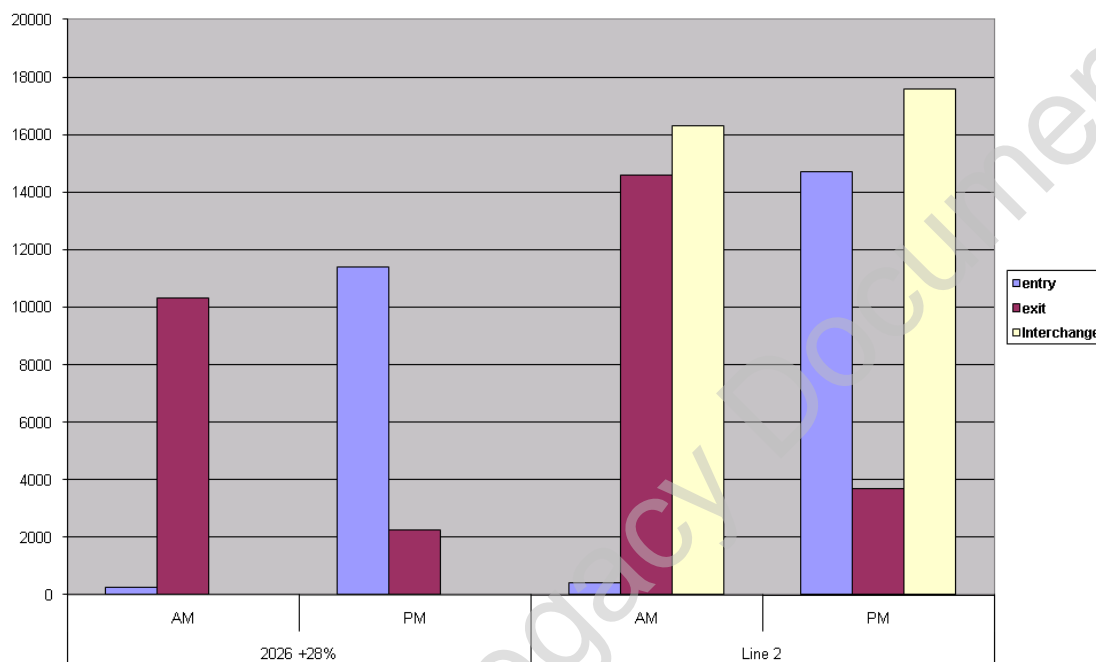

16.5 Routing Assumptions

Most of the routing assumptions are contained in the matrix. It has generally been assumed that the western part of TCR station will handle 50% of Line 2 to Crossrail interchange and 100% of Dean Street exits. All LUL interchange will be through the eastern concourse of TCR station.

16.6 Results

The results are shown for AM and PM peak periods for escalators, passageways and gatelines in the western half of TCR station in **Tables 7** and **8**. The peak period demand is converted into one minute flows and factors from LU's 1-371 are used to determine the required size of each element.

Figure 71: Station Elements - TCR West

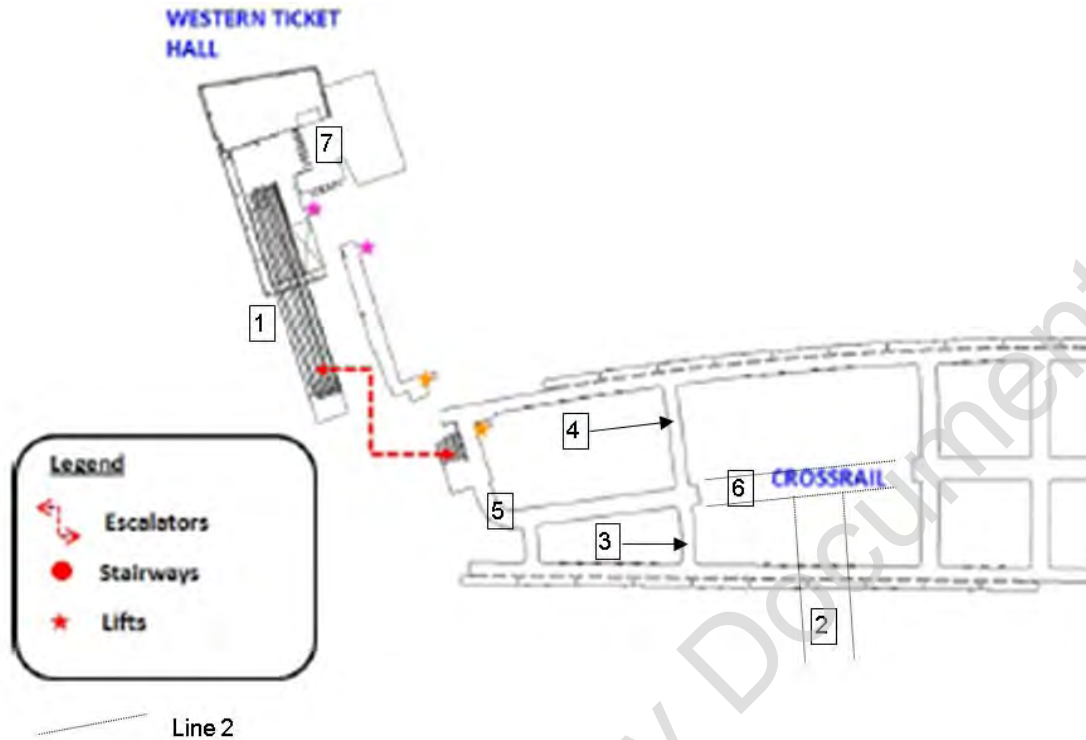

Table 13: Static Analysis Results (TCR West) - AM Peak

Ref	Station Element	AM pk period	1 min flow	Required	Provided	Compliance
	Escalator		@100ppm/m			
1	TCR Dean St to Crossrail UP	18,636	151	2	2	✓
	TCR Dean St to Crossrail DOWN	406	3	1	1	✓
2	Crossrail Concourse to Line 2 UP	16,900	137	2	2	✓
	Crossrail Concourse to Line 2 DOWN	7,750	63	1	2	✓
	Passageway Width		@40ppm/m			
3	Adit from Crossrail EB to Western concourse	7,811	63	2.00	4.5	✓
4	Adit from Crossrail WB to Western concourse	14,931	121	3.02	4.5	✓
5	Central Concourse to Western TH escalators	19,042	154	3.86	6.0	✓
6	Crossrail Concourse for Line 2 escalators	20,750	168	4.20	7.7	✓
	Gateline		@25ppm			
7	Dean St Ticket Hall to, Crossrail and Line 2 - EXIT	18,636	181	9	9	✓

Table 14: Static Analysis Results (TCR West) - PM Peak

Ref	Station Element	PM pk period	1 min flow	Required	Provided	Compliance
	Escalator		@100ppm/m			
1	TCR Dean St to Crossrail UP	3,690	26	1	1	✓
	TCR Dean St to Crossrail DOWN	18,724	133	2	2	✓
2	Crossrail Concourse to Line 2 UP	10,400	74	1	2	✓
	Crossrail Concourse to Line 2 DOWN	16,250	115	2	2	✓
	Passageway Width		@40ppm/m			
3	Adit from Crossrail EB to Western concourse	16,636	118	2.96	4.5	✓
4	Adit from Crossrail WB to Western concourse	9,828	70	2.00	4.5	✓
5	Central Concourse to Western TH escalators	22,414	159	3.98	6.0	✓
6	Crossrail Concourse for Line 2 escalators	22,350	159	3.97	7.7	✓
	Gateline		@25ppm			
7	Dean St Ticket Hall to, Crossrail and Line 2 - EXIT	3,690	31	10	9	✗

16.7 Summary

The static analysis results show that all the station components in the western part of Tottenham Court Road Station except for the gateline comply with LUL station planning standards with Line 2 demand included.

The Western Ticket Hall requires an additional gate in the PM Peak to cater for the Line2 demand. It should be noted that the gateline is constrained by the introduction, in CPFR 5, of a specific requirement to provide a 2.5m wide access corridor behind the POMs. Accommodation of additional gates may require some reconfiguration of the ticket hall, including encroachment into adjacent retail space.

The static calculations provide an appropriate level of understanding of the impacts on the western ticket hall from the delivery of Line 2, given the limited knowledge regarding the scope and delivery of Line 2.