

INTEGRATION

Procedure for Interface Management

Document Number: CRL1-XRL-O8-GPD-CR001-50001

Current Document History:

Revision:	Effective Date:	Author(s) (‘Owner’ in eB *)	Reviewed by: (‘Checked by’ in eB *)	Approved by:	Reason for Issue:
5.0	07/09/2017	George Georgiou	Mike Evans	Jeremy Bates	2 Year Review

Previous Document History:

Revision	Prepared / Effective Date:	Author:	Reviewed by:	Approved by:	Reason for Issue
1.0	21/07/11	George Georgiou	David Duncombe	Chris Sexton	For Implementation
1.1	16/01/12	George Georgiou	David Duncombe	Chris Sexton	For Acceptance, incorporates CAG comments
2.0	16/05/12	George Georgiou	David Duncombe	Chris Sexton	For Implementation
3.0	11/07/12	George Georgiou	Steve Maddock	David Duncombe	Addition of over site development
4.0	24/11/14	George Georgiou	Mike Evans	Jeremy Bates	For Implementation

Revision Changes:

Revision	Status / Description of Changes
5.0	This document has been reviewed and is fit for continued use.

Contents

1.	PURPOSE	1
2.	SCOPE	1
3.	DEFINITIONS & ABBREVIATIONS	1
4.	RESPONSIBILITIES	3
5.	PROCEDURE	4
5.1	INTRODUCTION.....	4
5.2	CONTEXT.....	4
5.3	STATIONS, SHAFTS, AND PORTALS INTERFACE MANAGEMENT	5
5.4	SYSTEMWIDE INTERFACE MANAGEMENT	6
	5.4.1. <i>Interface Requirements Specifications</i>	7
	5.4.2. <i>Detailed Interface Requirements</i>	7
	5.4.3. <i>Interface Actions and Progress</i>	8
	5.4.4. <i>Alignment to Design Reviews</i>	8
5.5	CANARY WHARF AND WOOLWICH STATIONS.....	8
5.6	MAINTAINING INTERFACE DESIGN CONFIGURATION.....	9
5.7	COVERAGE ANALYSIS	9
5.8	OVER SITE DEVELOPMENT AND STATIONS	9
	5.8.1. <i>Introduction</i>	9
	5.8.2. <i>Safeguarding the OSD Interface</i>	9
	5.8.3. <i>Building Regulations Compliance</i>	10
	5.8.4. <i>Inspection of OSD Scope and Interfaces</i>	11
	5.8.5. <i>OSD Planning Applications</i>	11
5.9	CONSTRUCTION INTERFACES	11
6.	INTERFACE DATABASE	12
6.1	RESPONSIBILITIES.....	12
6.2	DATABASE FEATURES.....	12
6.3	VERIFICATION.....	12
7.	RECORDS AND DELIVERABLES FOR SYSTEMWIDE	12
8.	REFERENCE DOCUMENTS	13
9.	STANDARD FORMS / TEMPLATES	13
10.	APPENDICES	13

1. Purpose

To ensure that Interface Management, undertaken by the Technical Directorate and those responsible for the design and development of the Crossrail project, is carried out in a planned, consistent and beneficial manner by the application of systems engineering practice.

This revision has been reviewed and is fit for continued use. The content has not changed.

2. Scope

This procedure addresses interface management undertaken on the design and engineering of Crossrail Central Section.

This procedure is applicable to all the systems, sub-systems, components and interfaces that make up the Crossrail Central Section, including all civil, and infrastructure elements plus interfaces to those elements located on the surface Western, North-Eastern and South-Eastern corridors (to be designed and installed by Network Rail) and rolling stock.

It is applicable to Framework Design Consultants and Design and Build Contractors (Systemwide as well as Stations, Shafts, and Portals - SS&P).

The interfaces can be categorized into the following four types;

- System Interfaces
- Physical Interfaces
- Information Interfaces
- Design-for-Construction Interfaces

The following types of interface are excluded from the scope of this plan:- Process Interfaces, Programme Interfaces, Requirements for Possessions, General Organisation and Management Communications, Operations Interfaces.

Asset protection does not fall under the scope of this procedure. The reader is referred to the following;

Infrastructure Protection Plan - London Underground Assets. [2]

Network Rail - Framework Asset Protection Agreement. [3]

DLRL - Works Agreement. [4]

These interfaces are managed by Others.

3. Definitions & Abbreviations

Boundary

A common physical separation between two systems or assets.

Interface Control Document

A management document formalizing an agreement between two or more systems or assets interface.

Interface

The point where two boundaries meet and a flow across the common boundary point takes place or a physical connection exists.

System interface

An interface between different systems involving an electrical and/or functional flow or influence. A functional test across that interface (integration test) is required in order to demonstrate the completion of that interface. (e.g. SCADA to ventilation system interface).

Physical interface

An interface where two systems physically meet but their completion does not require a systems integration test. (E.g. Connection of Bored tunnel to Station Box)

Information interface

An interface involving the exchange of information between interfacing parties (e.g. settlement data, or common design item designs).

Design-for-Construction interface

Where a design is required to incorporate interface features to allow construction to take place, e.g. staging, or TBM traversal. This is limited to design interfaces.

Interfacing party

A contractor, consultant, agent or representative responsible for the design or implementation of specific parts of the project works, which have a boundary with any other parts of the project. Also referred to as Others.

System

A collection of assets and people designed to work together to achieve a recognisable function.

Requirements

Used in terms such as Detailed Interface *Requirements*. In this context it relates to needs and constraints imposed across interface boundaries to ensure correct interfacing, and not to user requirements.

Abbreviations

BH	Berkley Homes
CRL	Crossrail Team
DIR	Detailed Interface Requirements
DLR	Docklands Light Railway
FDC	Framework Design Consultant

C-ICD	Construction Interface Control Document
GRIP	Governance for Railway Investment Projects; (8 stage process used by NR)
CWG	Canary Wharf Group
ICD	Interface Control Document
IFC	Issued For Construction
IRS	Interface Requirements Specifications
LAI	Licensed Approved Inspector
LU	London Underground
MEP	Mechanical, Electrical, and Public Health
NR	Network Rail
OSD	Over Site Development
PDP	Project Delivery Partner (prior to re-organisation)
RIBA	Royal Institute of British Architects, used in this procedure to refer to a lifecycle stage)
SCADA	Supervisory Control And Data Acquisition
SS&P	Stations, Shafts, and Portals

4. Responsibilities

Please refer to the Organisation charts in Connect Online.

CRL Interface Engineer

The CRL Interface Engineer (part of the Integration team) has overall responsibility for the interface engineering and management process including this Procedure and related templates and tools.

Support to CRL in establishing the completeness of interfaces identified and the high level progress towards interface definition and agreement.

Design Consultants

Design Consultants, including FDCs, Systemwide, and SS&P Design and Build Contractors, who have been employed to undertake design activities, are responsible for the management, identification, and specification of all interfaces in accordance with the process and requirements stated within this procedure.

Engineering Managers

Also known as Project Engineers, Head of Discipline, or Lead Engineers. For a given scope of works, responsible for supporting CRL in managing interfaces to ensure their integration with interfacing designs, systems and infrastructures of Others. Indicate acceptance of agreed ICDs and other interface documents by means of the decal (by both Engineering Managers representing the interfacing parties).

Provide support and interface management data to the CRL Interface Engineer.

Interfacing Parties (eg NR, DLR)

In accordance with the appropriate project development agreements, Industry Partners are required to co-operate at interface boundaries to identify, develop, and agree the interface designs.

5. Procedure

Introduction

- 5.1 This procedure provides a description of the process to be followed and the deliverables to be produced as part of the interface management work-streams to ensure that the Crossrail central section is correctly interfaced and integrated.

Context

5.2

The current design and interface development phase is characterised as:-

Systemwide Design and Build Contractors are developing designs in accordance to the performance specifications in the respective Works Information including the coordination of their designs with Others. Part 29, Volume 2B of the Works Information stipulates the high level process. They will produce interface documentation as per section 5.4.

SS&P Design and Build Contractors are constructing civil engineering structures based on completed designs (RIBA F, Gate 3) from the FDCs, and developing MEP/Architectural finish designs to RIBA F based on RIBA E designs from the FDCs. Part 7, Volume 2B of the Works Information stipulates the high level process. ICDs relating to the MEP and architecture design completion are therefore to be 'owned' and updated by the SS&P Contractors in line with the developing design. New ICDs shall be produced if more appropriate.

ICDs are also being used to cover the definition and agreement with Interfacing Parties such as NR, Rolling Stock etc unless other forms of agreements have been made, such as the use of Design Interface Statements for DLR and the Depot Interface Specification for the maintenance depot by C160.

This is illustrated in the diagram below (note 30/60/90 % annotations only refer to Systemwide);

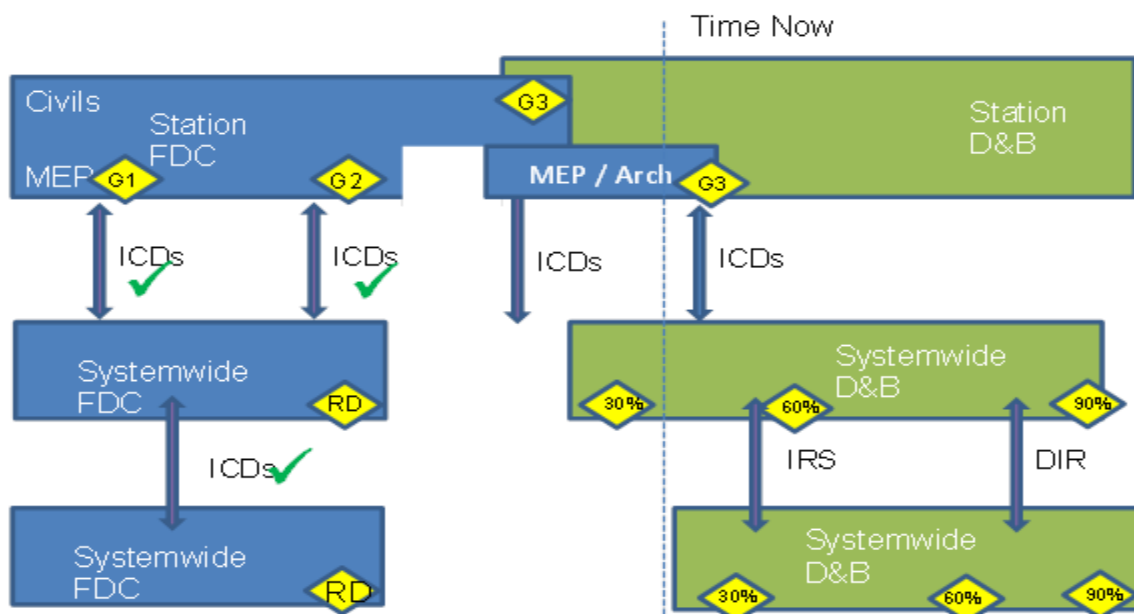

5.3 Stations, Shafts, and Portals Interface Management

This section covers the management of interfaces that relate to a 'civil engineering' package of works such as stations, shafts, portals, and tunnels. This predominately comprises physical and constructional interfacing with a significant element of spatial coordination and space proofing. This includes design interfaces with London Underground and Network Rail.

All existing FDCs and each new Design and Build Contractor contributing to the design and construction processes shall adhere to the interface management process described in the appropriate Works Information. This shall include the submission of a designer's interface management plan wherever stipulated in the contract. At the commencement of design, the boundaries or extent of the systems and assets being developed for a given workpackage shall be established by the responsible designer and documented, and all design interfaces identified. These shall be made available to the CRL Interface Engineer to analyse coverage of interface identification.

As detailed design is brought to completion, it is important that the interface information is captured and maintained. The Interface Control Document template [A] is to be used for detailed design to ensure that the appropriate level of detail is captured during the final design stage.

It is good practice to lodge and maintain draft ICDs on the CRL electronic document management system to allow others to understand the level of progress being made.

During development, the Contractor shall keep and maintain an interface log/ action tracker which shall include the list of interface documents (actual and anticipated), status, and issues being tracked.

Where necessary, design teams shall continue to form working groups to develop interface designs and record agreements in interface control documents. The emphasis shall be on the identification and co-ordination of the important characteristics, parameters and configurations that need to be developed to deliver effective interfaces. The level of detail documented in the ICDs must be proportionate with the level of detail being developed in the workpackage design outputs. All completed and agreed interface control documents shall be published via the CRL electronic document management system and key data made available for input to the CRL interface database.

Interfaces internal to a contract package shall be included within the respective designer's detailed designs and deliverables but do not ordinarily require an ICD, unless one of the following circumstances applies:-

- The interface is particularly complex, and is better managed via an ICD,
- CRL specifically request an ICD for the interface.

Once an interface has been specified and agreed between both interfacing parties, representatives from both sides of the interface shall sign the ICD and place it under formal document control. ICDs shall also be signed (usually by 'Decal') by the Engineering Managers representing both the interfacing Contractors/FDCs. Only decal codes 1, 2, or 3 are to be used as appropriate. The ICDs shall be updated prior to the Gate reviews so as to provide assurance that coordination has taken place. See ref [2].

ICDs shall meet the following requirements;

- Be simple, concise, and up to date
- Clearly explain the interface being documented and its geography/location
- Align and document the alignment of designs on each side of the demarcation.
- Refer to the design produced by the Contractors/FDCs (eg drawings, specifications, etc). References must be precise, ie document, ref number, revision, and if a large document, the relevant section.
- Include details of CAD models exchanged as appropriate
- Stipulate the interface design responsibilities and demarcation for both parties
- Focused on a manageable portion of an interface
- Be a collaborative effort authored by the leading interface party and with the interfacing party contributing supporting material.
- Not include eMails or Minutes of Meetings; any key information should be in the body of the ICD.

Once agreed, any required changes to the design or reference documents which could impact the specification of the interface (e.g. from a changed requirement or new revision of a standard) shall be brought to the attention of the interfacing party, agreed, and the ICD updated to reflect the change. The revised ICD shall be signed off by both parties, and the CRL interface database updated. Any issues that the Contractors/FDCs fail to resolve and is beyond their power must be brought to the attention of the CRL Engineering Managers for escalation.

As FDCs demobilise, there is a need for interim interface management responsibilities until the follow-on design/build contractors are mobilised. Where this occurs, the CRL Engineering Managers shall;

- Respond to queries from interfacing FDCs.
 - Implement document updates relating to interfaces and any impacted design items.
 - Attend Inter Design-consultant Reviews.
 - Conduct, or procure impact analysis (design and specialisms) on significant interface changes.
- 5.4
- Report on status of issues and ICD sign-off.
 - Request and obtain specialist assistance when required to support tasks above.

Systemwide Interface Management

This section covers the management of interfaces that relate to a 'systems' package of works such as signalling, communications, power distribution, etc . This predominately comprises electrical and functional interfacing.

The Contractor prepares a fully coordinated and integrated design with respect to all disciplines, system, interfaces, and design outputs from Others and interfacing 3rd party organisations such as London Underground and Network Rail.

The Contractor shall describe his interface management process in his Interface Management Plan or Design Management Plan, so as to reflect the process and requirements in this procedure.

The Contractor identifies design interfaces with Others, identifies the requirements of the interface in conjunction with Others, and provides suitable designs for the interfaces within the Detailed Design. The list of interfaces is captured in his Design Statement and must cover the Interface Matrices and supporting text included in the Works Information.

The Contractor manages design of interfaces through:

- Ongoing liaison, including regular technical interface meetings, with Others undertaking interfacing design to resolve incomplete, ambiguous or conflicting design input requirements, and raise Interface Actions to track their closure.
- Participation in design reviews with Others undertaking interfacing design.
- Reviews of design documents produced by Others undertaking interfacing design.
- Where designated as the owner, production and maintenance of Interface Requirements Specifications (IRS) and Detailed Interface Requirements (DIR).
- ICDs are not mandated for system to system interface definition between Systemwide contractors.

The Contractor shall notify the Project Manager of the failure of any interfacing party to cooperate or any other cause of delay to the development of an interface as soon as it occurs

5.4.1. Interface Requirements Specifications

The Interface Requirements Specification (unless a DIR is used instead) serves, for the interfacing parties, as the definitive reference for the characteristics of the interface including boundary, functional, performance, design input, and design constraint requirements.

The IRS shall be authored by the owner as designated in the Interface Matrices and other interface information found in the Works Information, and collaboratively supported by the interfacing party or parties. The IRS shall provide for the Interfacing parties to confirm acceptance through signature.

The IRS captures the requirements and constraints that each Contractor has on the interfacing Contractor. The Contractors produce a design based on the requirements: outputs may take various forms including System Design Specification, Layout Drawing, etc. The lead Contractor manages the interface design and liaising with the interfacing Contractor as required under the Contract.

The IRS shall be simple and concise, clearly explaining the interface being documented. Where appropriate, it must be aligned and refer to the design produced by the Contractor and Others undertaking the interfacing design. It must stipulate the interface design responsibilities and demarcation for each party. The level of detail in the IRS must reflect the complexity of the interface.

5.4.2. Detailed Interface Requirements

Detailed Interface Requirements (DIRs) documents are reserved for the more complex functional interfaces which require significant integration of design.

The DIR shall be authored by the owner as designated in the Interface Matrices, and collaboratively supported by the interfacing party or parties. The DIR shall have the provision to allow the Interfacing parties to confirm acceptance through signature.

The DIRs shall clearly describe the interface, including

- requirements and constraints,
- data flows
- cross-boundary functions,
- protocols and sequencing,
- degraded modes of operations

5.4.3. Interface Actions and Progress

The process of developing and agreeing interfaces will commonly result in queries and actions that need to be resolved. These may come as a result of reviewing interface designs or specifications, formal design reviews, or the development of IRS or DIR documents.

Where such interface queries or disagreements cannot be clarified immediately and require an action, the Contractor shall raise an action and capture it within a tracker.

The tracker shall be maintained and kept up to date by the Contractor and shall include the action description, who raised the action and who is responsible for closure, target date, and status.

This tracker can be a dedicated interface action tracker, or included in other Contractor action trackers, but must clearly identify/tag the action as an interface action. The tracker must be provided to the Project Manager as part of the design progress meetings.

A summary Interface Report of progress for interface management shall be provided in the Contractor's monthly design progress report. This shall include a listing of all interface documentation produced, status, key issues, and planned mitigation.

5.4.4. Alignment to Design Reviews

The development of the Systemwide interfaces shall be aligned to the design technical assurance review stages, and progress presented and assessed against the criteria established for the 30%, 60%, and 90% stage Design Gate Review. Progress will be checked per package per design gate stage.

5.5

Canary Wharf and Woolwich Stations

Canary Wharf group are in contract with CRL to provide a design for, and construct, the new Crossrail station at Canary Wharf. For the purposes of interface management, the provisions made under the applicable Development Agreements are to be followed. Interfacing is facilitated through the CRL Design Interface Manager CW & BH. There are a number of technical interfaces between the station works, which are to be designed and constructed by CWG and the Rail Systems' works to be delivered by CRL. These were agreed in the Development Agreements and any changes from that have been by formal instruction. The development of the interfaces has been through interface meetings and by the review/comments of CWG design submissions.

Berkeley Homes have provided the new Crossrail station box at Woolwich. For the purposes of interface management, the provisions made under the applicable Development Agreements are to be followed. Interfacing is facilitated through the ME Woolwich Station and the CRL Design Interface Manager CW & BH. The station box to tunnel interface is subject to the appropriate C122 ICD. The reference [6] should be consulted as it describes the primary structural interfaces between the fit-out structure designed and built by CRL (C158) and the station box designed and built by Berkeley Homes.

Maintaining Interface Design Configuration

Maintaining a robust design configuration is important across the whole design including the interfaces. The reader is referred to the Design Management Process [11], and the Post IFC Changes Guidance Note [12].

The Gates Procedure requires that any design change post-IFC requiring a revision of the original Gate, effectively needs the same level of co-ordination establishing as was the case for the original gated design.

Where a proposal to change a design post-Gate III is made, there is a requirement to review the proposed change against the original design configuration, i.e. to ascertain whether the original Interface Control Documents and IDR/IDC information has changed such that the design of other interfacing parties may have been impacted. It is important that Engineering Managers ensure that Contractors/FDCs (Designers) are completing this assessment correctly and undertaking the necessary actions.

It is anticipated that to support Gate Impact Reports, and maintaining design configuration, there is a probability of needing to update and sign-off Interface Control Documents (ICDs), and providing evidence that interface review meetings having taken place and IDCs re-established if appropriate.

5.7 **Coverage Analysis**

An analysis to verify that all technical interfaces had been identified by the Framework Design Consultants and that they were being managed was completed in 2010, and the results reported in reference [5].

For the phase covered by this Procedure, coverage will be assured in two stages. The first is by the identification of interfaces which are then captured within the Works Information provided to the Contractors. This work is conducted by CRL Engineering Managers under the appropriate procedures, and the products take the form of interface matrices and supporting text. The second stage will be managed by the CRL Interface Engineer in conjunction with the Engineering Managers. It will consist of an analysis through the use of a Master Interface Matrix to identify all the interfaces and that they are being developed and managed. This analysis matrix will be used to provide metrics for the project periodic reports.

Over Site Development and Stations

5.8.1. Introduction

This section is intended to set out the arrangements for managing the interface between OSD's and Crossrail works during the detailed design and construction phase of the Crossrail works

It is intended primarily for internal Crossrail use and will also be issued to Crossrail's OSD Collaboration Partners. Where in this section OSD designers are referred to, this includes members of Collaboration Partners design teams.

This procedure does not change the CDM arrangements given in 'Construction (Design & Management) Regulations 2007 Implementation Plan for Over Site Developments', Doc No CRL1-PDP-O3-TPL-CRG03-00003 [7].

5.8.2. Safeguarding the OSD Interface

The Construction Contractor's design is managed by Crossrail Engineering Managers representing the Chief Engineers Group, located on site, reporting to the Crossrail Project Manager

The Station Designer (FDC) will be retained by Crossrail on 'Construction Phase Support – Type A' call off NEC Option E (Cost Reimbursable) contracts to respond to contractor queries and to ensure that the contractors design satisfies the original intent of the FDC design.

The interface between the OSD and station is documented in an Interface Control Document (ICD), agreed between the station and OSD design teams. The ICD is a living document and will be updated as appropriate by the Station FDC

In general, OSD designs have been taken to RIBA C for Planning Applications and will be temporarily put on hold until a developer commits to take forward the development rights. Further design development will generally commence shortly before the sites are available for OSD development.

The ICD will form the basis of a further document entitled Technical Interface Parameters' (TIP) which will form a part of the agreement Crossrail will enter into with OSD Developers.

It is recognised that the interface between the station and OSD may change through either design development or design changes during the station construction phase.

Relatively minor developments or changes to the station design can have a significant adverse impact on the value of the site if the OSD interface is compromised.

The OSD Team and the Engineering Managers require the ability to review and agree any design development or design changes which impact on the OSD interface This will occur via existing processes including Change Control (if appropriate) and participation in, and signing off IDR's.

The OSD Team recognises that the requirements of the operational works are paramount

The Station Engineering Manager and OSD Team will monitor design development and proposed changes and identify any instance where the OSD interface is potentially impacted.

The Station Engineering Manager and OSD Team will seek input from the interfacing party to the review and approval of design development or design changes which impact on the OSD interface.

For Non-Collaboration sites, the OSD review will be carried out by the OSD designers procured via the FDC's

For Collaboration sites, the OSD review will be carried out by the Collaboration Partners Design Team, managed by the Crossrail OSD Team.

The ICD will be updated by the FDC to reflect the agreed design development and any change.

5.8.3. Building Regulations Compliance

Certain elements of OSD structure can only be installed during the construction of the railway works. Schedule 2 of the Crossrail Act permits this and most station construction contracts include OSD scope.

In some instances this OSD scope is delivered by a combination of both the Advance Works and the Main Works Contractors and is described in CRL1-XRL-T2-RSW-CRG02-00001 [8].

The Crossrail Act exempts the need for Building Regulation Approval for railway works but not for OSD scope.

The Crossrail OSD Team has procured the services of an Approved Building Regulations Licensed Approved Inspector (LAI) to satisfy this requirement

The OSD LAI has a schedule of all OSD scope which he will inspect during construction and provide a certificate on completion.

The OSD LAI will make contact with the station Project Manager to agree the 'hold points' for inspection.

The OSD Team and LAI will liaise on a regular basis with the Crossrail Project Field Engineer (Supervisor Representative)

The Crossrail Project Field Engineer will notify the OSD Team and the OSD LAI when agreed 'hold points' are ready for inspection.

5.8.4. Inspection of OSD Scope and Interfaces

The OSD Team will carry out inspections of:

- (i) OSD scope delivered under Schedule 2 of the Crossrail Act, and
- (ii) Specific items of station scope at the OSD interface, examples of which are given below:
 - OSD Beam & Column connections (couplers, RC details, HD bolts, anchor plates etc)
 - Details of permanent cladding junction between OSD and station
 - Details of fixing for temporary cladding to be replaced by OSD
 - Details of OSD M&E earthing plates
 - Lightning protection connections
 - GSHP pipework detailed design and terminations and connections
 - GSHP pipework pressure and thermal test results

The OSD Team will liaise with the station Construction Manager to arrange site visits by relevant OSD Designers as appropriate.

The OSD Team will record the findings of the inspection and issue a report to the station Construction Manager.

5.8.5. OSD Planning Applications

The process for approval of OSD planning applications is described in Process for Approval of OSD Planning Applications (CR-XRL-T2-GPC-CR001-00015) [9]. This ensures that the interfaces with both internal and external stakeholders are considered prior to the submission of a planning application to the relevant Local Planning Authority.

Construction Interfaces

The management and process of construction interfaces is controlled by Field Engineering and is described in the document Construction Interface Management Procedure [10].

It details the roles and responsibilities of the Delivery Team and Contractor for carrying out interface management and highlights the use of Construction Interface Control Document (C-ICD) to capture details and agreements.

6. Interface Database

Responsibilities

6.1 The Contractors/FDCs shall continue to manage and track their own interface logs and issues databases. This shall contain sufficient information and be made available to CRL on a periodic basis to allow the CRL Interface Engineer to populate the CRL Interface Database.

Database Features

6.2 The CRL interface database is kept on SharePoint and provides the following fields;

Title

Status (active ICD, IRS, DIR, superseded, etc)

Lead Contractor

Interfacing Contractor

Scorecard (Agreed, Agreed but Developing, Draft)

Revision/Date (per appropriate Gate)

Decal

Link (hyperlink to eB)

Notes.

A screen shot of is provided in the appendix of a typical view of the database. Further information can be provided on request to the CRL Interface Engineer.

6.3

Verification

Interface verification includes the review and sign-off of ICDs (including decal by CRL), but also the completion of SDRs, IDRs, and subsequent review certification. The Engineering Managers representing each side of the interface are also required to sign-off the ICDs.

7. Records and Deliverables for Systemwide.

	First period of Contract	30% Stage	60% Stage	90% Stage
Interface management process (or as part of Design Management Plan)	x			
Interface Log and Tracker (every period)	-	-	-	-
Interface Requirements Specification			x	x
Detailed Interface Requirements			x	x

8. Reference Documents

Ref:	Document Title:	Document Number:
1.	Engineering Design Assurance Gates Procedure	CRL1-XRL-O7-GPD-CR001-50015
2.	Infrastructure Protection Plan - London Underground Assets	CRL1-XRL-N2-STP-CR001-50003
3.	Network Rail - Framework Asset Protection Agreement	CR-XRL-Z8-AAG-CR001-00132
4.	DLRL - Works Agreement	CRL1-XRL-T2-XWP-CRG03-00019
5.	Interface Coverage Report	CRL1-PDP-O8-RGN-CRG03-00049
6	Fit-out Structure Primary Interfaces with the Station Box	C158-OVE-S-RGN-CR147-50001
7	Construction (Design & Management) Regulations 2007 Implementation Plan for Over Site Developments	CRL1-PDP-O3-TPL-CRG03-00003
8	Building Regulations Scope for OSD Elements Incorporated in Station Works	CRL1-XRL-T2-RSW-CRG02-00001
9	Process for the Approval of OSD Planning Applications	CR-XRL-T2-GPC-CR001-00015
10	Construction Interface Management Procedure	CRL1-XRL-N2-GPD-CR001-50006
11	Design Management Plan Template	CRL1-XRL-O7-ZTM-CR001-50011
12	Post IFC (Issued for Construction) Changes Internal Guidance Note	CRL1-XRL-O7-GUI-CR001-50001

9. Standard Forms / Templates

Ref:	Document Title:	Document Number:
A.	Detailed Design Interface Control Document RIBA (or GRIP) Level X (Template)	CR-XRL-N2-ZTM-CR001-00001

10. Appendices

Appendix: Interface Database Screen-shot

Requirements and Integration > **ICD Progress Chart** > View by Lead FDC ▾

Home Company Information ▾ Organisations Applications ▾ My HR CMS Cross-train Contact Details This List: ICD Progress Chart

	Status	Lead FDC	Interfacing FDC	Scorecard	Title	RIBA D	RIBA E	RIBA F	Decal	Link
Lead FDC : C300 (2)										
Lead FDC : C336 (1)										
Lead FDC : C340 (5)										
Active	C340	C610	1	C340-VIN-N2-AAG-CR144_PT003-50001 VDP and C610 Track			y2 1-5-14			https://eb.crossrail.co.uk/eb/Search/QuickLink.aspx?n=C340-VIN-N2-AAG-CR144_PT003-50001&t=3&d=Main%5ceBProd&sc=Global&state=LatestRevision&i=view
Active	C340	C610	1	C340-VIN-N2-AAG-CR144_PT003-50008 C610 OHLE			y2 21-5-14			https://eb.crossrail.co.uk/eb/Search/QuickLink.aspx?n=C340-VIN-N2-AAG-CR144_PT003-50008&t=3&d=Main%5ceBProd&sc=Global&state=LatestRevision&i=view
Active	C340	C610	1	C340-VIN-N2-AAG-CR144_PT003-50009 C610 MEP			y2 3-6-14	code 4		https://eb.crossrail.co.uk/eb/Search/QuickLink.aspx?n=C340-VIN-N2-AAG-CR144_PT003-50009&t=3&d=Main%5ceBProd&sc=Global&state=LatestRevision&i=view
Active	C340	C650	1	C340-VIN-N2-AAG-CR144_PT003-50002 VDP C650			V2 20-3-14			
Active	C340	C660	1	C340-VIN-N2-AAG-CR144_PT003-50003 VDP and C660			y2 3-2-14			
Lead FDC : C350 (14)										
Lead FDC : C360 (9)										
Lead FDC : C405 (16)										

ICD Progress Chart - C340-VIN-N2-AAG-CR144_PT003-50008 C610...

View

Version History Alert Me

Edit Item Manage Permissions Delete Item

Manage Actions

Title	C340-VIN-N2-AAG-CR144_PT003-50008 C610 OHLE
Status	Active
Lead FDC	C340
Interfacing FDC	C610
Scorecard	1
RIBA D	
RIBA E	
RIBA F	y2 21-5-14
Decal	
Link	https://eb.crossrail.co.uk/eb/Search/QuickLink.aspx?n=C340-VIN-N2-AAG-CR144_PT003-50008&t=3&d=Main%5ceBProd&sc=Global&state=LatestRevision&i=view
Notes	

Created at 02/12/2013 04:53 PM by George Georgiou
 Last modified at 22/05/2014 04:33 PM by George Georgiou

Close